

SO SERIES OUTSIDE CORNERS

SAMPLE SPECIFICATION

specify as: SOFTFORMS® Model # SO-X-XXX

Pitcon SOFTFORMS® LLC

6409 Rhode Island Avenue	3330 W. Flower Street
Riverdale, MD 20737	Phoenix, AZ 85017
(800) 637-7638	(800) 637-7638
(301) 927-1000	(602) 233-9100
Fax: (301) 699-8690	Fax: (602) 233-9400

The extruded aluminum profile shall incorporate a continuous integral fin for surface contact to conventionally installed gypsum drywall. The fins shall be 7/8" wide and shall be tapered to the edge. The tapered fins shall be punched with holes staggered to accept standard screw fastening. A series of continuous grooves shall be extruded into the face of the fins to provide greater bonding surface. The extruded profiles shall be primed with corrosion-resistant primer compatible with materials normally in use in conjunction with commercial interiors, i.e.: joint compound, latex and enamel paints, and wall covering adhesives.

MATERIAL: Aluminum alloy.....6063 T5 or equal
Finish.....Factory primed

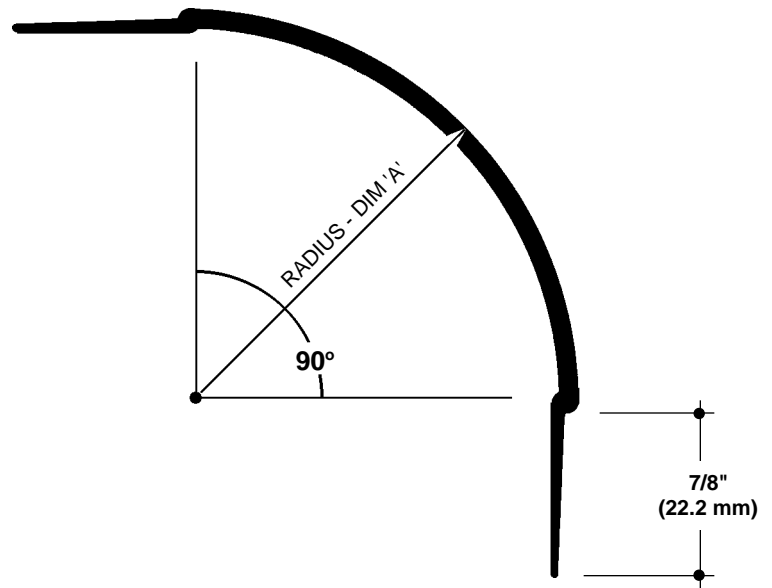

SO SERIES
NO SCALE

OUTSIDE CORNER
TYPICAL SECTION

SELECTING YOUR SOFTFORMS® SO SERIES OF ALUMINUM EXTRUSIONS

Select proper SOFTFORMS extrusion from the ordering information shown below.

Model Number	Radius
SO-9-050	1/2" (12.7 mm)
SO-9-063	5/8" (15.9 mm)
SO-9-075	3/4" (19.1 mm)
SO-9-100	1" (25.4 mm)
SO-9-150	1-1/2" (38.1 mm)
SO-9-200	2" (50.8 mm)
SO-9-250	2-1/2" (63.5 mm)
SO-9-300	3" (76.2 mm)
SO-9-400	4" (101.6 mm)

Note:

Special custom sizes are also available. Check with factory for availability and lead time.

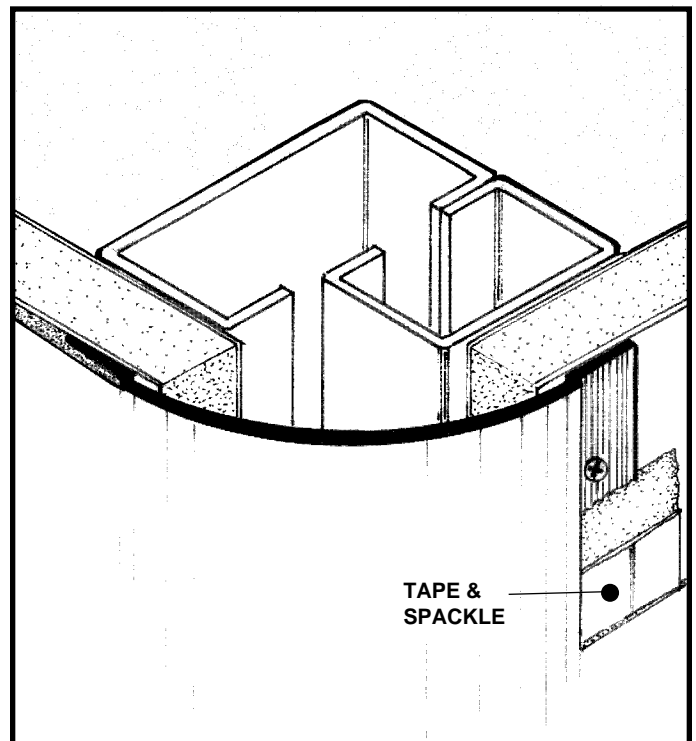

All details, methods and specifications are the exclusive property of Pitcon Softforms® LLC. Pitcon reserves the right to change any specifications or details without prior notification. All Softforms® profiles are available in standard 10' lengths ±1/8" (2.048 M). Other lengths are available as special order items. For custom shapes, sizes, or for special finishes, please contact the factory or your nearest Pitcon sales representative.

SO SERIES OUTSIDE CORNERS

SELECTING YOUR SOFTFORMS® SO SERIES OF ALUMINUM EXTRUSIONS

Select proper SOFTFORMS extrusion from the ordering information shown below.

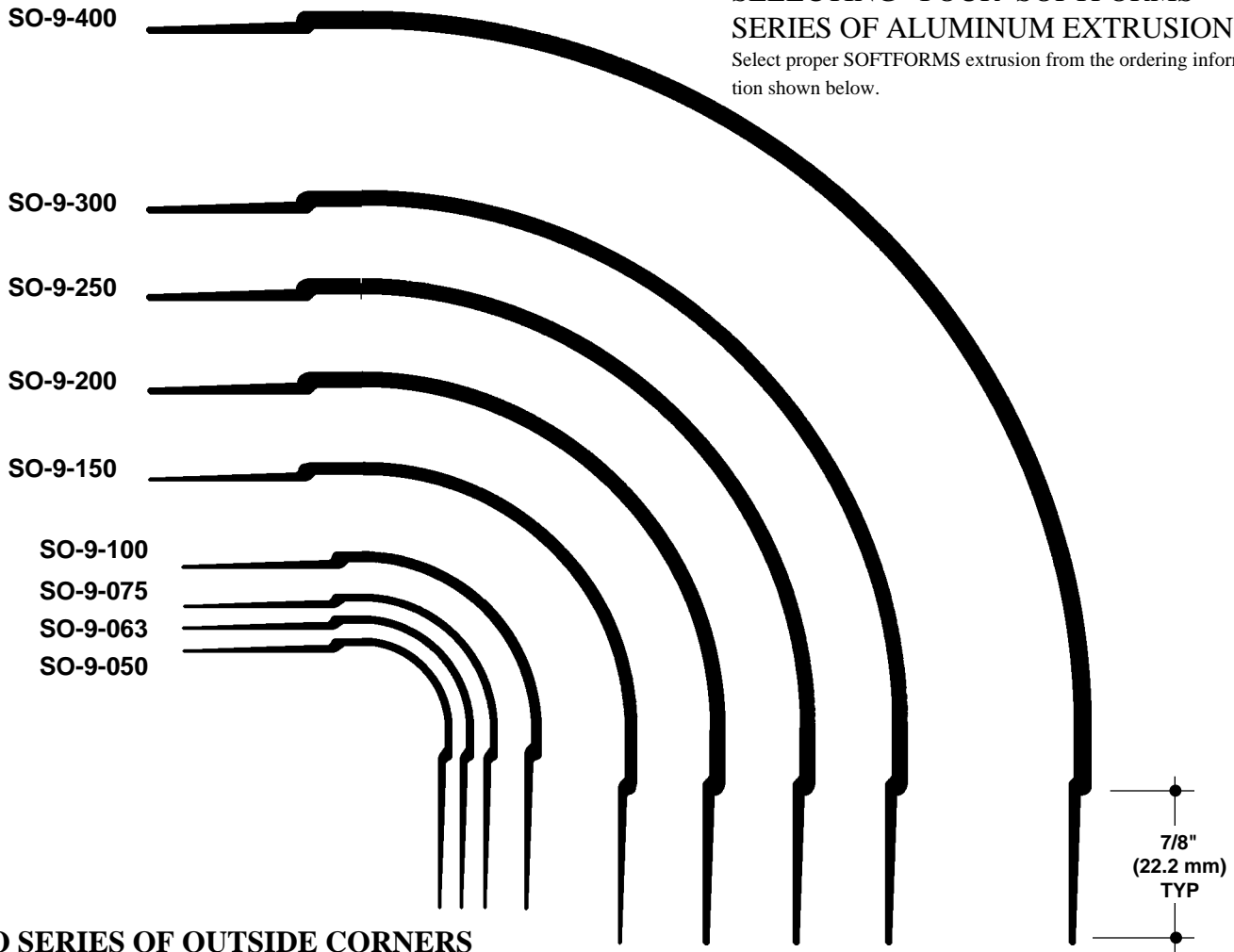

SO SERIES OF OUTSIDE CORNERS
NO SCALE

EXAMPLE DETAIL

For use with conventional metal stud construction and 1/2" or 5/8" GPDW.

Metal studs at corner conditions will allow the SO SERIES of outside corner to work with the standard metal track. Optional ceiling trims for acoustical tile support are available in either a pre-finished white or primed for field finishing. Screws through the grooved fins must always engage metal or wood substructure to ensure proper installation.

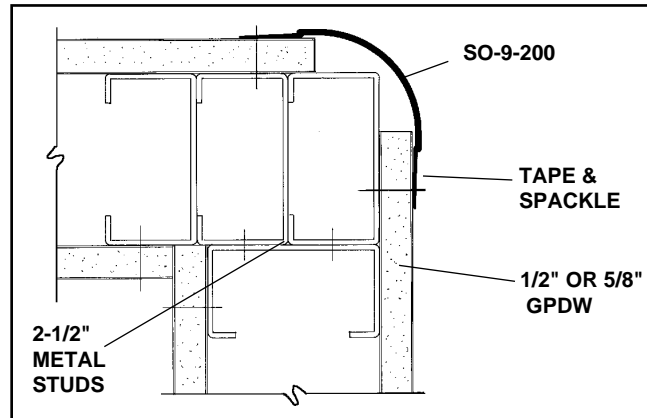

Pittcon SOFTFORMS® LLC

6409 Rhode Island Avenue
Riverdale, MD 20737
(800) 637-7638
(301) 927-1000
Fax: (301) 699-8690

3330 W. Flower Street
Phoenix, AZ 85017
(800) 637-7638
(602) 233-9100
Fax: (602) 233-9400

Softforms®
PREFORMED ARCHITECTURAL PROFILES
FOR DRYWALL CONSTRUCTION

SO-HSE-90

HIGH STRENGTH CORNER

SAMPLE SPECIFICATION

specify as: SOFTFORMS® Model # SO-HSE-90

Pittcon SOFTFORMS® LLC

6409 Rhode Island Avenue	3330 W. Flower Street
Riverdale, MD 20737	Phoenix, AZ 85017
(800) 637-7638	(800) 637-7638
(301) 927-1000	(602) 233-9100
Fax: (301) 699-8690	Fax: (602) 233-9400

The extruded aluminum profile shall incorporate a continuous integral fin for surface contact to conventionally installed gypsum drywall. The fins shall be 7/8" wide and shall be tapered to the edge. The tapered fins shall be punched with holes staggered to accept standard screw fastening. A series of continuous grooves shall be extruded into the face of the fins to provide greater bonding surface. The extruded profiles shall be primed with corrosion-resistant primer compatible with materials normally in use in conjunction with commercial interiors, i.e.: joint compound, latex and enamel paints, and wall covering adhesives.

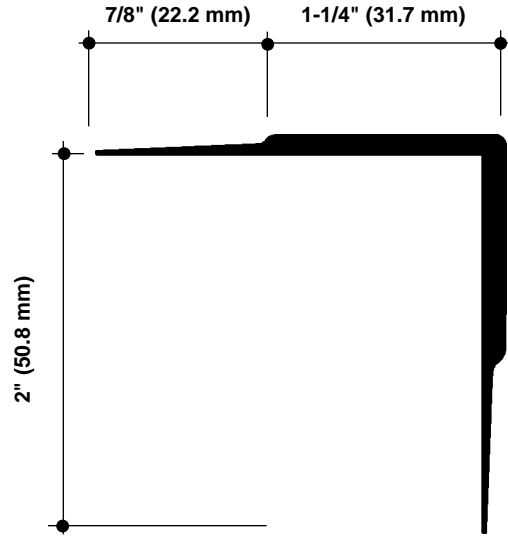

MATERIAL: Aluminum alloy.....6063 T5 or equal
Finish.....Factory primed

SO-HSE-90
NO SCALE

HIGH STRENGTH CORNER
SECTION

EXAMPLE DETAIL

For use with conventional metal stud construction and 2 layers of 1/2" or 5/8" fire rated GPDW.

The SO-HSE-90 provides a high strength corner bead and can be applied to standard corner framing. They are the perfect solution for applications in high traffic areas where damage normally occurs to corner beads. Screws through the grooved fins must always engage metal or wood substructure to ensure proper installation.

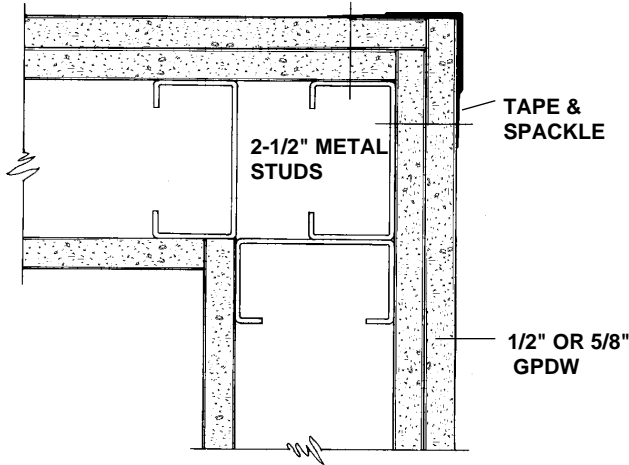

SO-HSE-90 + 2-1/2" STUD WALL
NO SCALE **PLAN/SECTION**

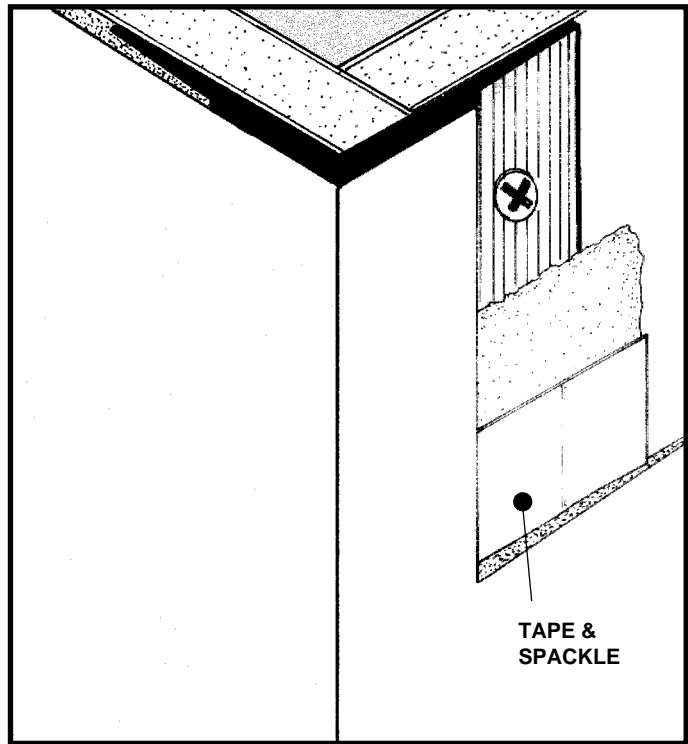

All details, methods and specifications are the exclusive property of Pittcon Softforms® LLC. Pittcon reserves the right to change any specifications or details without prior notification. All Softforms® profiles are available in standard 10' lengths ±1/8" (2.048 M). Other lengths are available as special order items. For custom shapes, sizes, or for special finishes, please contact the factory or your nearest Pittcon sales representative.

Softforms®

PREFORMED ARCHITECTURAL PROFILES
FOR DRYWALL CONSTRUCTION

SO 36

SO-R060-90

FABRIC TUCK CORNER

SAMPLE SPECIFICATION

specify as: SOFTFORMS® Model # SO-R060-90

Pitcon SOFTFORMS® LLC

6409 Rhode Island Avenue	3330 W. Flower Street
Riverdale, MD 20737	Phoenix, AZ 85017
(800) 637-7638	(800) 637-7638
(301) 927-1000	(602) 233-9100
Fax: (301) 699-8690	Fax: (602) 233-9400

The extruded aluminum profile shall incorporate a continuous integral fin for surface contact to conventionally installed gypsum drywall. The fins shall be 7/8" wide and shall be tapered to the edge. The tapered fins shall be punched with holes staggered to accept standard screw fastening. A series of continuous grooves shall be extruded into the face of the fins to provide greater bonding surface. The extruded profiles shall be primed with corrosion-resistant primer compatible with materials normally in use in conjunction with commercial interiors, i.e.: joint compound, latex and enamel paints, and wall covering adhesives.

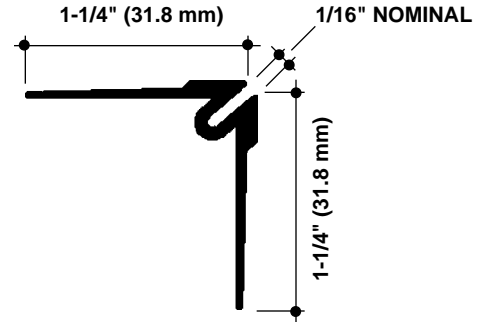

MATERIAL: Aluminum alloy.....6063 T5 or equal
Finish.....Factory primed

SO-R060-90
NO SCALE

90° OUTSIDE CORNER
WITH FABRIC TUCK

EXAMPLE DETAIL

For use with conventional metal stud construction and 1/2" or 5/8" GPDW.

The SO-R060-90 permits a concealed joint for dissimilar wall coverings which meet at a 90° intersection. The wall coverings are inserted by means of a thin "pizza wheel" tool. A small amount of adhesive in the reveal is desirable to prevent any pull away. Screws through the grooved fins must always engage metal or wood substructure to ensure proper installation.

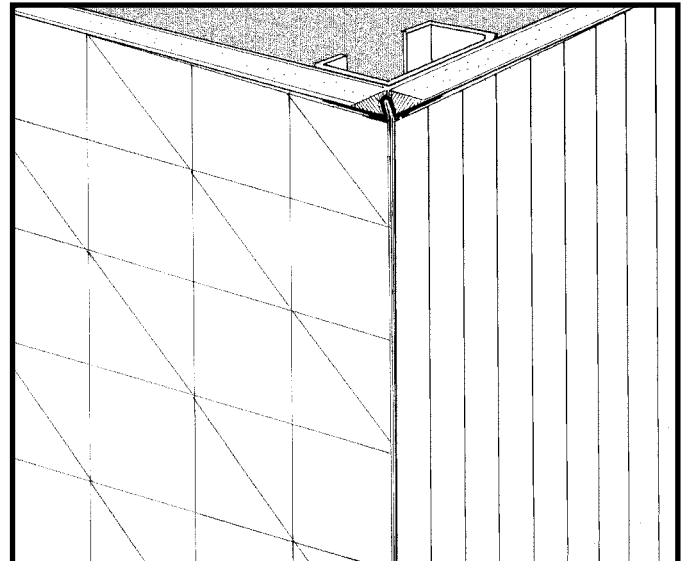
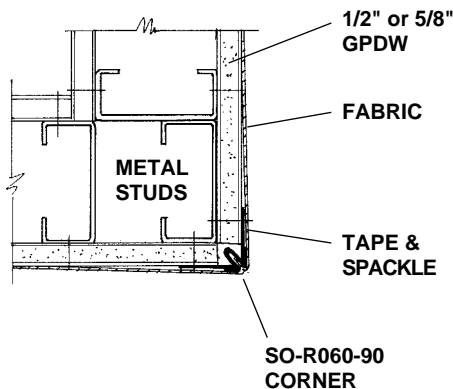

NOTE:
WHEN TUCKING EDGES OF WALLCOVERING INTO CHANNEL, ALWAYS APPLY MASTIC FIRST TO ENSURE THAT PROPER BONDING IS MADE. USE CAUTION NOT TO SCORE OR TEAR EDGES OF WALLCOVERING WHEN TUCKING.

SO-R060-90 + 2-1/2" STUD WALL

NO SCALE

PLAN/SECTION

All details, methods and specifications are the exclusive property of Pitcon Softforms® LLC. Pitcon reserves the right to change any specifications or details without prior notification. All Softforms® profiles are available in standard 10' lengths ±1/8" (2.048 M). Other lengths are available as special order items. For custom shapes, sizes, or for special finishes, please contact the factory or your nearest Pitcon sales representative.

Softforms®

PREFORMED ARCHITECTURAL PROFILES
FOR DRYWALL CONSTRUCTION

SO 37

SO-ER-90

CORNER WITH REVEAL

SAMPLE SPECIFICATION

specify as: SOFTFORMS® Model # SO-ER-90

Pittcon SOFTFORMS® LLC

6409 Rhode Island Avenue
Riverdale, MD 20737
(800) 637-7638
(301) 927-1000
Fax: (301) 699-8690

3330 W. Flower Street
Phoenix, AZ 85017
(800) 637-7638
(602) 233-9100
Fax: (602) 233-9400

The extruded aluminum profile shall incorporate a continuous integral fin for surface contact to conventionally installed gypsum drywall. The fins shall be 7/8" wide and shall be tapered to the edge. The tapered fins shall be punched with holes staggered to accept standard screw fastening. A series of continuous grooves shall be extruded into the face of the fins to provide greater bonding surface. The extruded profiles shall be primed with corrosion-resistant primer compatible with materials normally in use in conjunction with commercial interiors, i.e.: joint compound, latex and enamel paints, and wall covering adhesives.

MATERIAL: Aluminum alloy.....6063 T5 or equal
Finish.....Factory primed

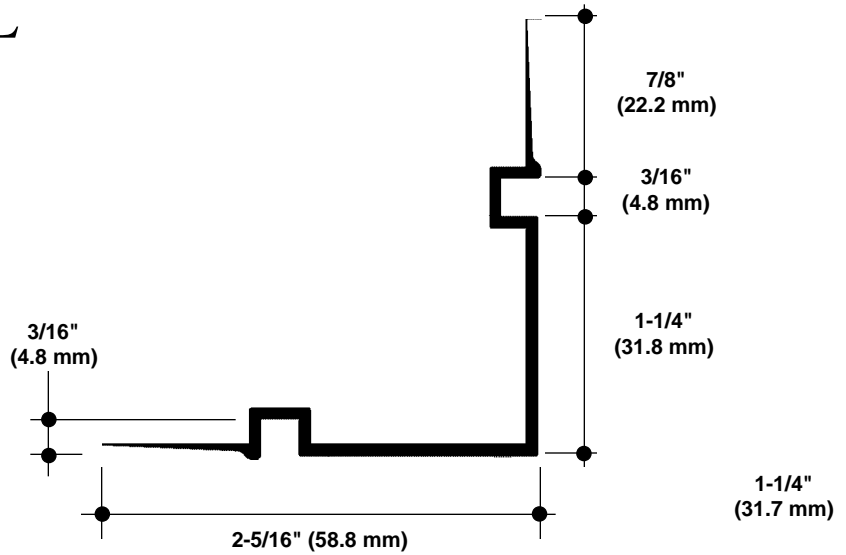

SO-ER-90
NO SCALE

CORNER WITH REVEAL
SECTION

EXAMPLE DETAIL

For use with conventional metal stud construction and 1/2" or 5/8" GPDW.

The SO-ER-90 provides a corner bead with built in decorative vertical reveals. This corner can be used in any instance where you wish to replace a standard square corner bead with a decorative feature. The vertical reveals can be painted in a complimentary color to the rest of the wall surface, or used isolate the corner itself. They are especially useful in separating different patterns or colors of vinyl wallcoverings. Screws through the grooved fins must always engage metal or wood substructure to ensure proper installation.

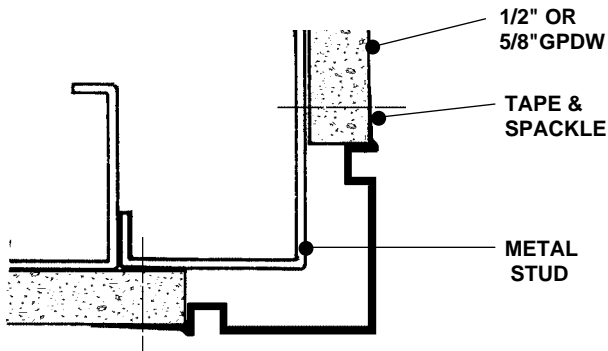

SO-ER-90
NO SCALE

STUD WALL
PLAN/SECTION

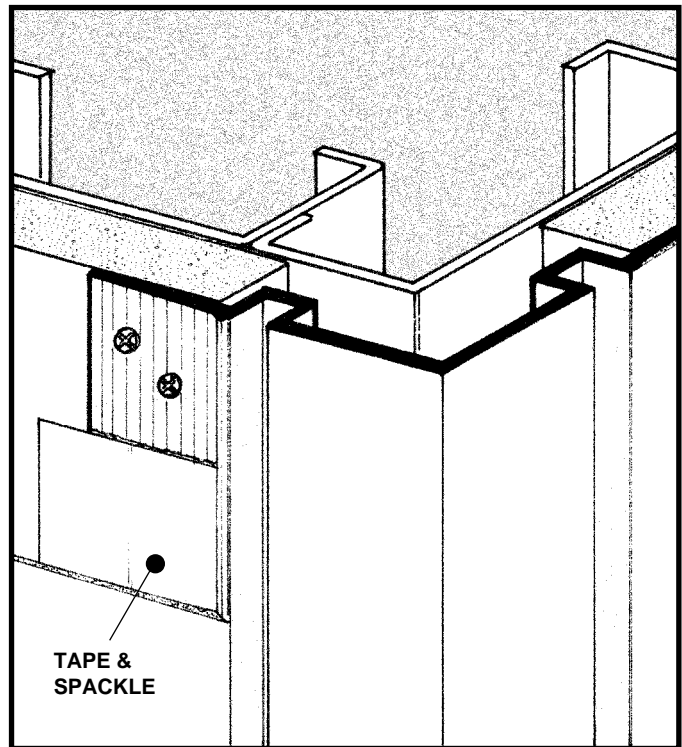

All details, methods and specifications are the exclusive property of Pittcon Softforms® LLC. Pittcon reserves the right to change any specifications or details without prior notification. All Softforms® profiles are available in standard 10' lengths ±1/8" (2.048 M). Other lengths are available as special order items. For custom shapes, sizes, or for special finishes, please contact the factory or your nearest Pittcon sales representative.

Softforms®

PREFORMED ARCHITECTURAL PROFILES
FOR DRYWALL CONSTRUCTION

SO 38

SO-45A

45° OUTSIDE CORNER

SAMPLE SPECIFICATION

specify as: SOFTFORMS® Model # SO-45A

Pitcon SOFTFORMS® LLC

6409 Rhode Island Avenue	3330 W. Flower Street
Riverdale, MD 20737	Phoenix, AZ 85017
(800) 637-7638	(800) 637-7638
(301) 927-1000	(602) 233-9100
Fax: (301) 699-8690	Fax: (602) 233-9400

The extruded aluminum profile shall incorporate a continuous integral fin for surface contact to conventionally installed gypsum drywall. The fins shall be 7/8" wide and shall be tapered to the edge. The tapered fins shall be punched with holes staggered to accept standard screw fastening. A series of continuous grooves shall be extruded into the face of the fins to provide greater bonding surface. The extruded profiles shall be primed with corrosion-resistant primer compatible with materials normally in use in conjunction with commercial interiors, i.e.: joint compound, latex and enamel paints, and wall covering adhesives.

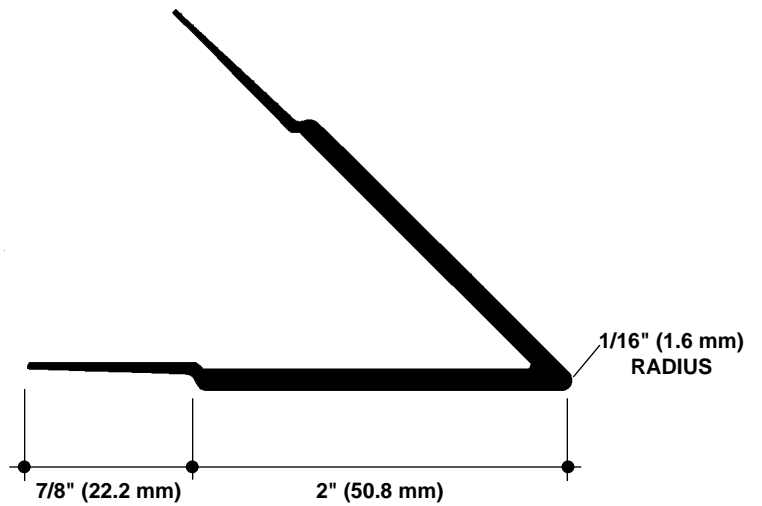

MATERIAL: Aluminum alloy.....6063 T5 or equal
Finish.....Factory primed

SO-45A
NO SCALE

45° OUTSIDE CORNER
SECTION

EXAMPLE DETAIL

For use with conventional metal stud construction and 1/2" or 5/8" GPDW.

The SO-45A provides a true and durable 45° corner. Screws through the grooved fins must always engage metal or wood substructure to ensure proper installation.

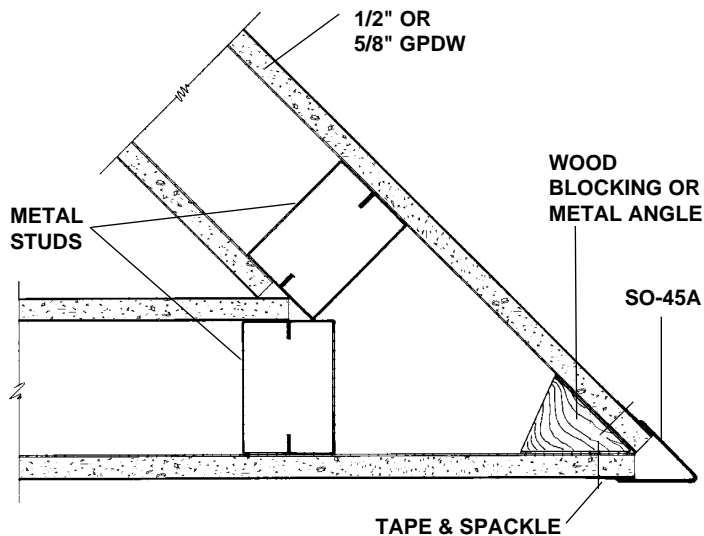

SO-45A + STUD WALL
NO SCALE

PLAN/SECTION

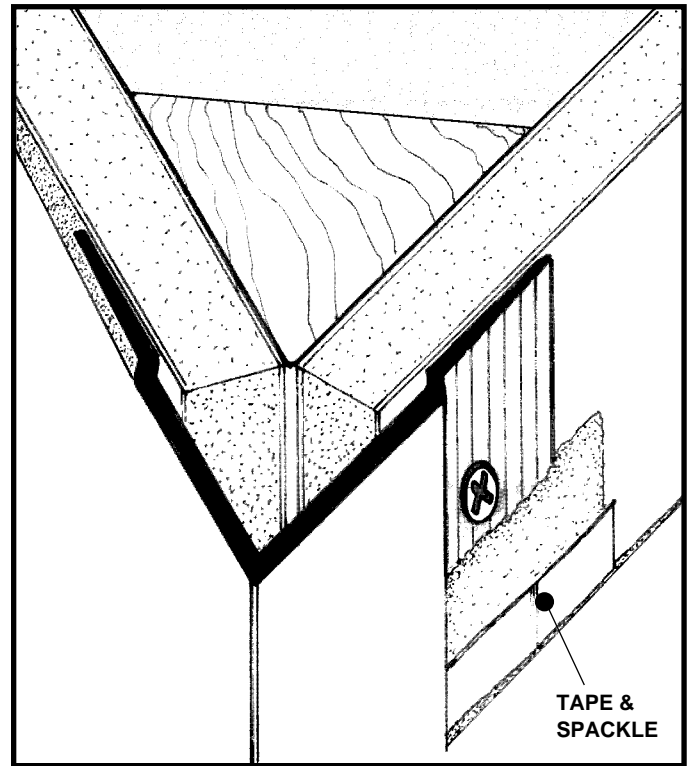

All details, methods and specifications are the exclusive property of Pitcon Softforms® LLC. Pitcon reserves the right to change any specifications or details without prior notification. All Softforms® profiles are available in standard 10' lengths ±1/8" (2.048 M). Other lengths are available as special order items. For custom shapes, sizes, or for special finishes, please contact the factory or your nearest Pitcon sales representative.

Softforms®

PREFORMED ARCHITECTURAL PROFILES
FOR DRYWALL CONSTRUCTION

SO-60A

60° OUTSIDE CORNER

SAMPLE SPECIFICATION

specify as: SOFTFORMS® Model # SO-60A

Pittcon SOFTFORMS® LLC

6409 Rhode Island Avenue
Riverdale, MD 20737
(800) 637-7638
(301) 927-1000
Fax: (301) 699-8690

3330 W. Flower Street
Phoenix, AZ 85017
(800) 637-7638
(602) 233-9100
Fax: (602) 233-9400

The extruded aluminum profile shall incorporate a continuous integral fin for surface contact to conventionally installed gypsum drywall. The fins shall be 7/8" wide and shall be tapered to the edge. The tapered fins shall be punched with holes staggered to accept standard screw fastening. A series of continuous grooves shall be extruded into the face of the fins to provide greater bonding surface. The extruded profiles shall be primed with corrosion-resistant primer compatible with materials normally in use in conjunction with commercial interiors, i.e.: joint compound, latex and enamel paints, and wall covering adhesives.

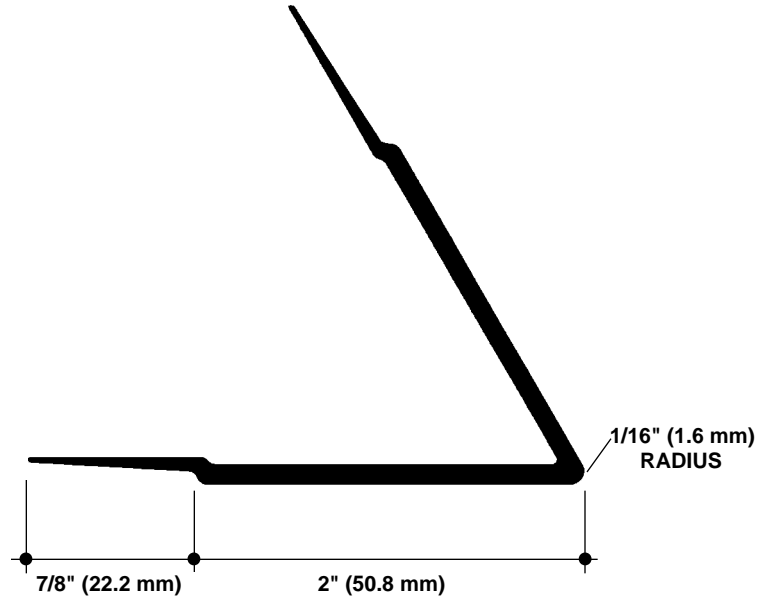

MATERIAL: Aluminum alloy.....6063 T5 or equal
Finish.....Factory primed

SO-60A
NO SCALE

60° OUTSIDE CORNER
SECTION

EXAMPLE DETAIL

For use with conventional metal stud construction and 1/2" or 5/8" GPDW.

The SO-60A provides a true and durable 60° corner. When combined with wood cabinetry the adjoining panels must be rabbeted to permit recessing the fins. These areas are finished with fiberglass body putty and feathered out. Screws through the grooved fins must always engage metal or wood substructure to ensure proper installation.

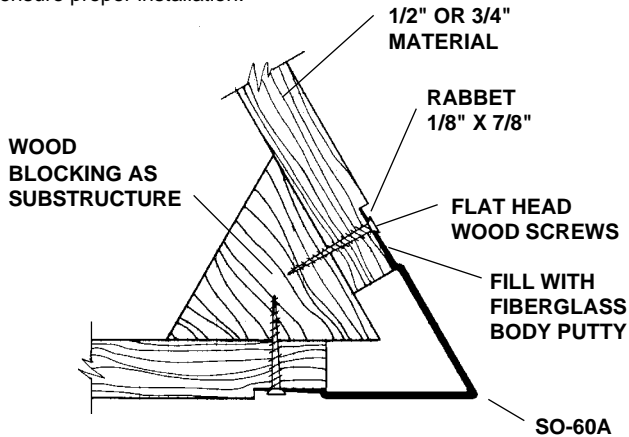

SO-60A @ PEDESTAL CORNER
NO SCALE **SECTION**

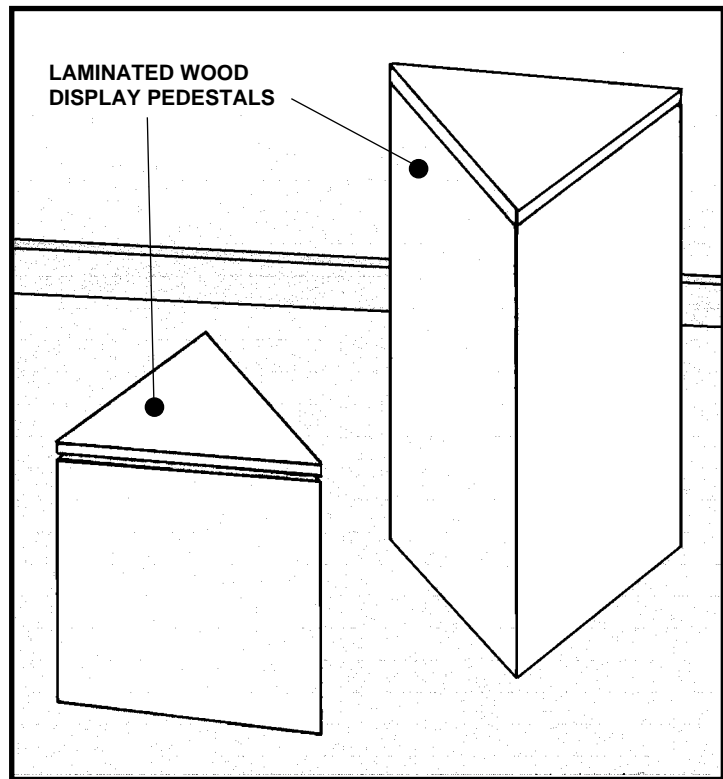

All details, methods and specifications are the exclusive property of Pittcon Softforms® LLC. Pittcon reserves the right to change any specifications or details without prior notification. All Softforms® profiles are available in standard 10' lengths ±1/8" (2.048 M). Other lengths are available as special order items. For custom shapes, sizes, or for special finishes, please contact the factory or your nearest Pittcon sales representative.

SO-9-075C

CHAMFERED CORNER

SAMPLE SPECIFICATION

specify as: SOFTFORMS® Model # SO-9-075C

Pitcon SOFTFORMS® LLC

6409 Rhode Island Avenue	3330 W. Flower Street
Riverdale, MD 20737	Phoenix, AZ 85017
(800) 637-7638	(800) 637-7638
(301) 927-1000	(602) 233-9100
Fax: (301) 699-8690	Fax: (602) 233-9400

The extruded aluminum profile shall incorporate a continuous integral fin for surface contact to conventionally installed gypsum drywall. The fins shall be 7/8" wide and shall be tapered to the edge. The tapered fins shall be punched with holes staggered to accept standard screw fastening. A series of continuous grooves shall be extruded into the face of the fins to provide greater bonding surface. The extruded profiles shall be primed with corrosion-resistant primer compatible with materials normally in use in conjunction with commercial interiors, i.e.: joint compound, latex and enamel paints, and wall covering adhesives.

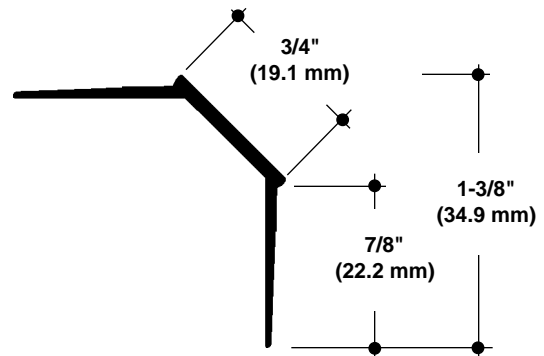

MATERIAL: Aluminum alloy.....6063 T5 or equal
Finish.....Factory primed

SO-9-075C
NO SCALE

CHAMFERED CORNER
SECTION

EXAMPLE DETAIL

For use with conventional metal stud construction and 1/2" or 5/8" GPDW.

Three metal studs at corner conditions will allow the SO-9-075C profile to work with the standard metal track. Screws through the grooved fins must always engage metal or wood substructure to ensure proper installation.

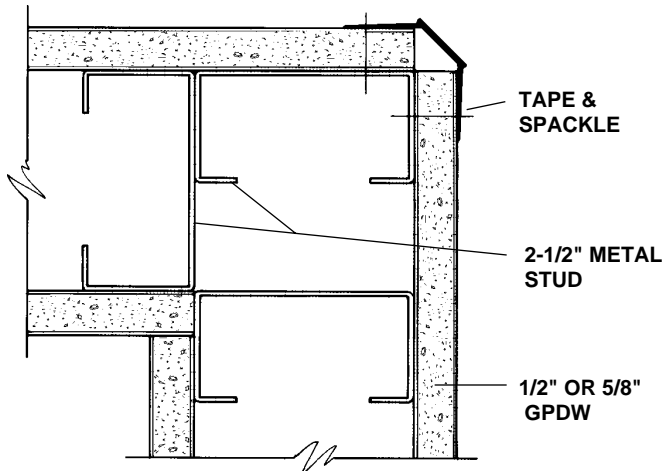

SO-9-075C + 2-1/2" STUD WALL
NO SCALE **PLAN/SECTION**

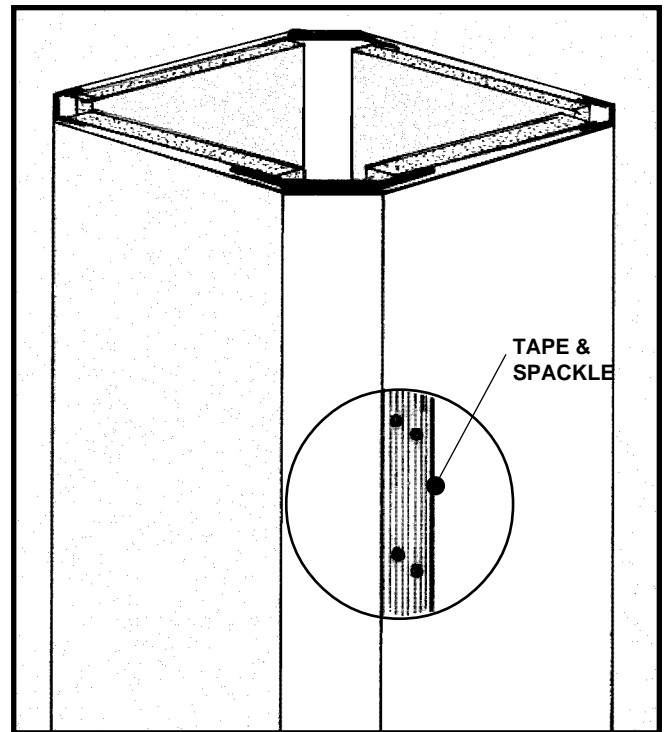

All details, methods and specifications are the exclusive property of Pitcon Softforms® LLC. Pitcon reserves the right to change any specifications or details without prior notification. All Softforms® profiles are available in standard 10' lengths ±1/8" (2.048 M). Other lengths are available as special order items. For custom shapes, sizes, or for special finishes, please contact the factory or your nearest Pitcon sales representative.

SOT-9-063

CORNER RETURN

SAMPLE SPECIFICATION

specify as: SOFTFORMS® Model # SOT-9-063

Pittcon SOFTFORMS® LLC

6409 Rhode Island Avenue
Riverdale, MD 20737
(800) 637-7638
(301) 927-1000
Fax: (301) 699-8690

3330 W. Flower Street
Phoenix, AZ 85017
(800) 637-7638
(602) 233-9100
Fax: (602) 233-9400

The extruded aluminum profile shall incorporate a continuous integral fin for surface contact to conventionally installed gypsum drywall. The fins shall be 7/8" wide and shall be tapered to the edge. The tapered fins shall be punched with holes staggered to accept standard screw fastening. A series of continuous grooves shall be extruded into the face of the fins to provide greater bonding surface. The extruded profiles shall be primed with corrosion-resistant primer compatible with materials normally in use in conjunction with commercial interiors, i.e.: joint compound, latex and enamel paints, and wall covering adhesives.

MATERIAL: Aluminum alloy.....6063 T5 or equal
Finish.....Factory primed

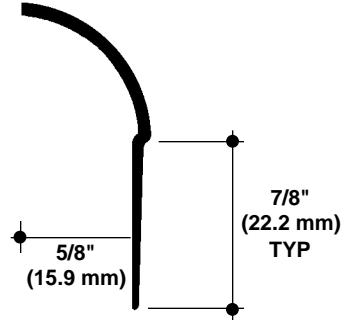

SOT-9-063
NO SCALE

5/8" RADIUS CORNER RETURN
SECTION

EXAMPLE DETAIL

For use with conventional metal stud construction and 1/2" or 5/8" GPDW.

The SOT-9-063 provides a quarter round transition from drywall to flush or recessed wood trim, or windows and doors, particularly in renovation work. Screws through the grooved fins must always engage metal or wood substructure to ensure proper installation.

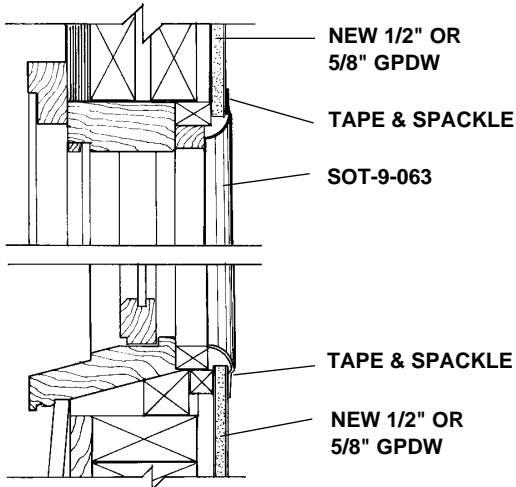

SOT-9-063 WINDOW FRAME DETAIL
NO SCALE SECTION

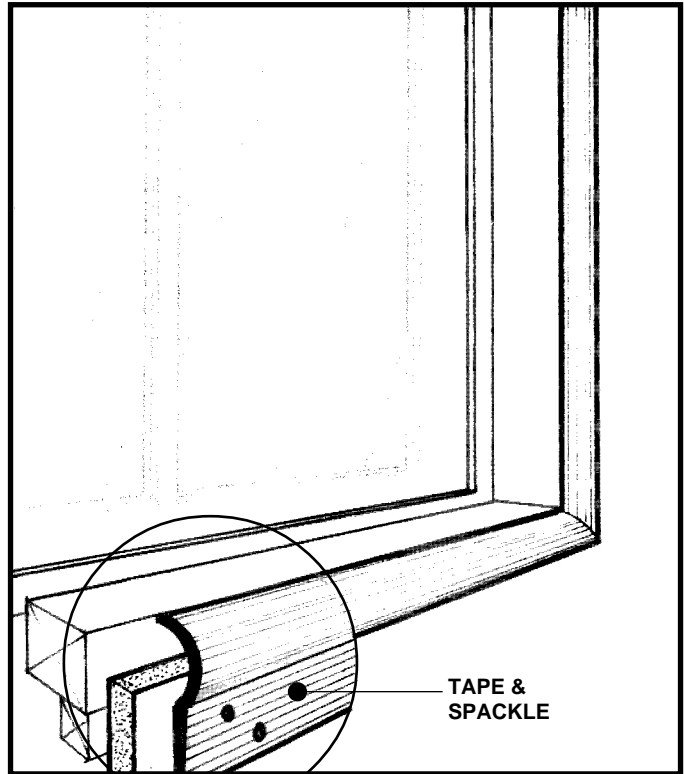

All details, methods and specifications are the exclusive property of Pittcon Softforms® LLC. Pittcon reserves the right to change any specifications or details without prior notification. All Softforms® profiles are available in standard 10' lengths $\pm 1/8"$ (2.048 M). Other lengths are available as special order items. For custom shapes, sizes, or for special finishes, please contact the factory or your nearest Pittcon sales representative.

SCS-2X(050-050)

DOUBLE CORNER STEP 1/2" x 1/2"

SAMPLE SPECIFICATION

specify as: SOFTFORMS® Model # SCS-2X(050-050)

Pittcon SOFTFORMS® LLC

6409 Rhode Island Avenue
Riverdale, MD 20737
(800) 637-7638
(301) 927-1000
Fax: (301) 699-8690

3330 W. Flower Street
Phoenix, AZ 85017
(800) 637-7638
(602) 233-9100
Fax: (602) 233-9400

The extruded aluminum profile shall incorporate a continuous integral fin for surface contact to conventionally installed gypsum drywall. The fins shall be 7/8" wide and shall be tapered to the edge. The tapered fins shall be punched with holes staggered to accept standard screw fastening. A series of continuous grooves shall be extruded into the face of the fins to provide greater bonding surface. The extruded profiles shall be primed with corrosion-resistant primer compatible with materials normally in use in conjunction with commercial interiors, i.e.: joint compound, latex and enamel paints, and wall covering adhesives.

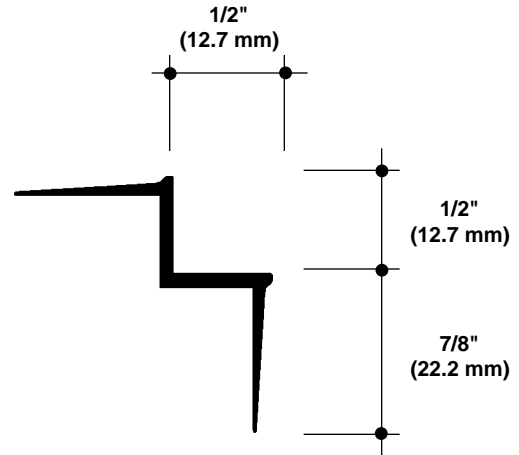

MATERIAL: Aluminum alloy.....6063 T5 or equal
Finish.....Factory primed

SCS-2X(050-050) 1/2" x 1/2" CORNER STEP
NO SCALE SECTION

EXAMPLE DETAIL

For use with conventional metal stud construction and 1/2" GPDW.

The SCS-2X(050-050) will permit a wide range of horizontal and vertical decorative treatments to walls, ceilings, soffits, column covers, etc. Screws through the grooved fins must always engage metal or wood substructure to ensure proper installation.

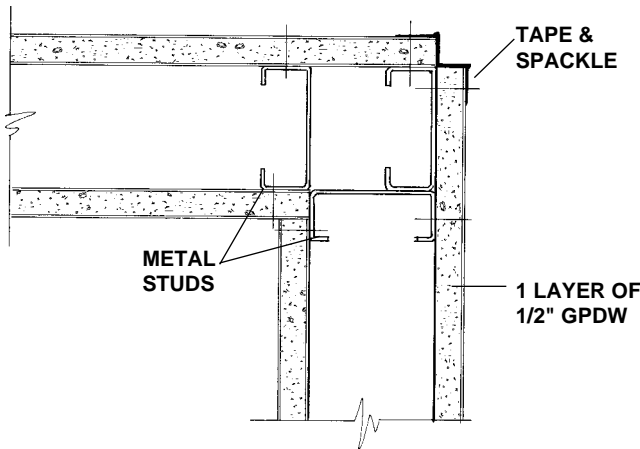

SCS-2X(050-050) & STUD WALLS
NO SCALE PLAN/SECTION

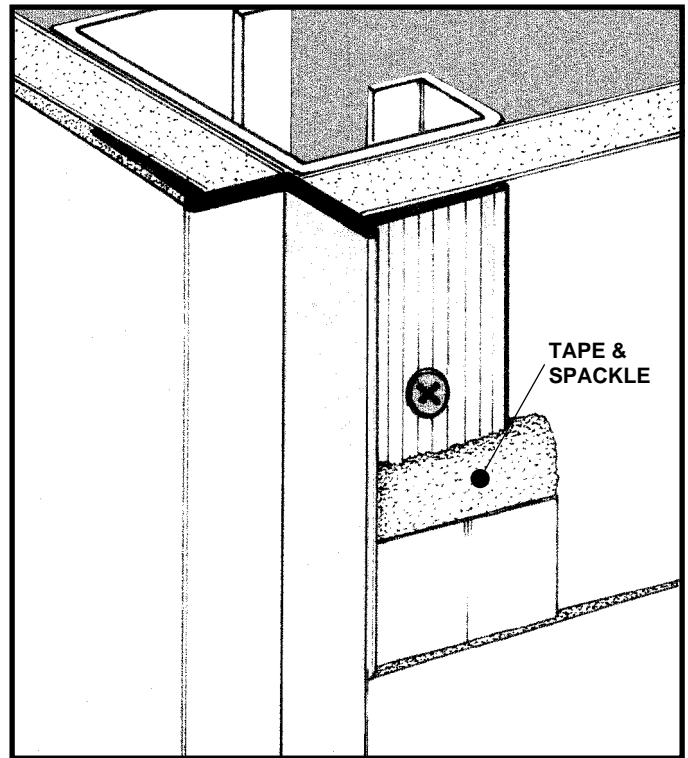

All details, methods and specifications are the exclusive property of Pittcon Softforms® LLC. Pittcon reserves the right to change any specifications or details without prior notification. All Softforms® profiles are available in standard 10' lengths ±1/8" (2.048 M). Other lengths are available as special order items. For custom shapes, sizes, or for special finishes, please contact the factory or your nearest Pittcon sales representative.

SCS-2X(063-063)

DOUBLE CORNER STEP 5/8" x 5/8"

SAMPLE SPECIFICATION

specify as: SOFTFORMS® Model # SCS-2X(063-063)

Pittcon SOFTFORMS® LLC

6409 Rhode Island Avenue Riverdale, MD 20737 (800) 637-7638 (301) 927-1000 Fax: (301) 699-8690	3330 W. Flower Street Phoenix, AZ 85017 (800) 637-7638 (602) 233-9100 Fax: (602) 233-9400
--	---

The extruded aluminum profile shall incorporate a continuous integral fin for surface contact to conventionally installed gypsum drywall. The fins shall be 7/8" wide and shall be tapered to the edge. The tapered fins shall be punched with holes staggered to accept standard screw fastening. A series of continuous grooves shall be extruded into the face of the fins to provide greater bonding surface. The extruded profiles shall be primed with corrosion-resistant primer compatible with materials normally in use in conjunction with commercial interiors, i.e.: joint compound, latex and enamel paints, and wall covering adhesives.

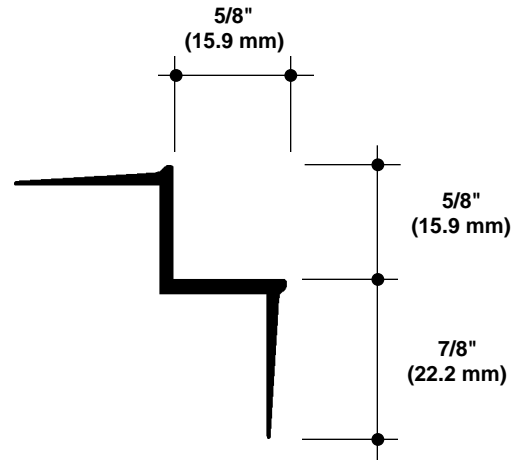

MATERIAL: Aluminum alloy.....6063 T5 or equal
Finish.....Factory primed

SCS-2X(063-063) 5/8" x 5/8" CORNER STEP
NO SCALE SECTION

EXAMPLE DETAIL

For use with conventional metal stud construction and 5/8" GPDW.

The SCS-2X(063-063) will permit a wide range of horizontal and vertical decorative treatments to walls, ceilings, soffits, column covers, etc. Screws through the grooved fins must always engage metal or wood substructure to ensure proper installation.

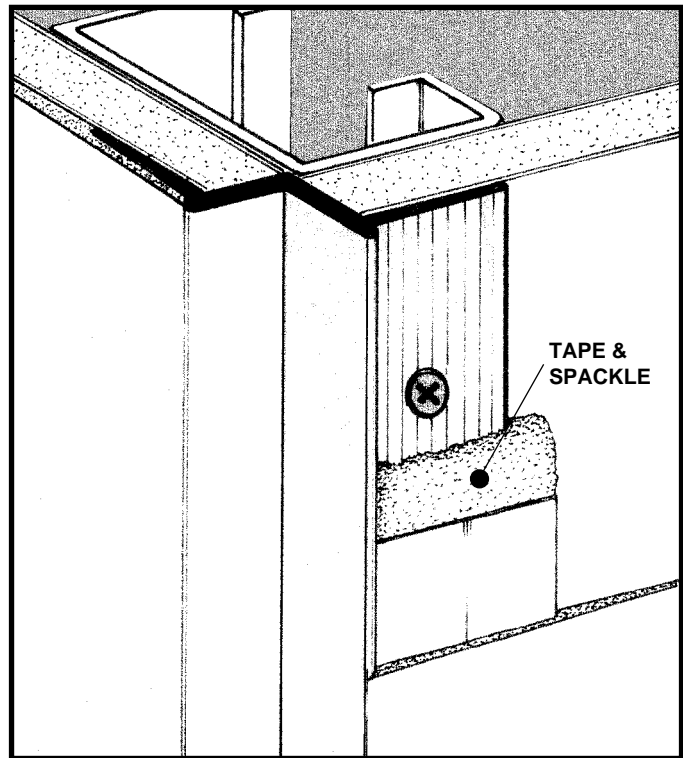
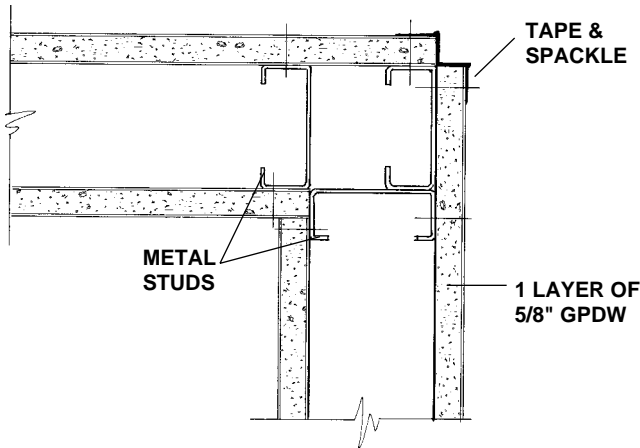

SCS-2X(063-063) & STUD WALLS
NO SCALE PLAN/SECTION

All details, methods and specifications are the exclusive property of Pittcon Softforms® LLC. Pittcon reserves the right to change any specifications or details without prior notification. All Softforms® profiles are available in standard 10' lengths $\pm 1/8"$ (2.048 M). Other lengths are available as special order items. For custom shapes, sizes, or for special finishes, please contact the factory or your nearest Pittcon sales representative.

SCS-2X(100-100)

DOUBLE CORNER STEP 1" x 1"

SAMPLE SPECIFICATION

specify as: SOFTFORMS® Model # SCS-2X(100-100)

Pitcon SOFTFORMS® LLC

6409 Rhode Island Avenue	3330 W. Flower Street
Riverdale, MD 20737	Phoenix, AZ 85017
(800) 637-7638	(800) 637-7638
(301) 927-1000	(602) 233-9100
Fax: (301) 699-8690	Fax: (602) 233-9400

The extruded aluminum profile shall incorporate a continuous integral fin for surface contact to conventionally installed gypsum drywall. The fins shall be 7/8" wide and shall be tapered to the edge. The tapered fins shall be punched with holes staggered to accept standard screw fastening. A series of continuous grooves shall be extruded into the face of the fins to provide greater bonding surface. The extruded profiles shall be primed with corrosion-resistant primer compatible with materials normally in use in conjunction with commercial interiors, i.e.: joint compound, latex and enamel paints, and wall covering adhesives.

MATERIAL: Aluminum alloy.....6063 T5 or equal
Finish.....Factory primed

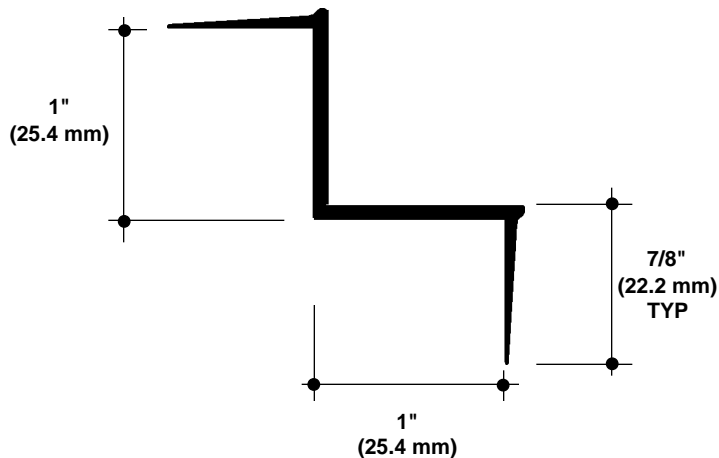

SCS-2X(100-100) 1" x 1" CORNER STEP
NO SCALE SECTION

EXAMPLE DETAIL

For use with conventional metal stud construction and 5/8" GPDW.

The SCS-2X(100-100) will permit a wide range of horizontal and vertical decorative treatments to walls, ceilings, soffits, column covers, etc. Screws through the grooved fins must always engage metal or wood substructure to ensure proper installation.

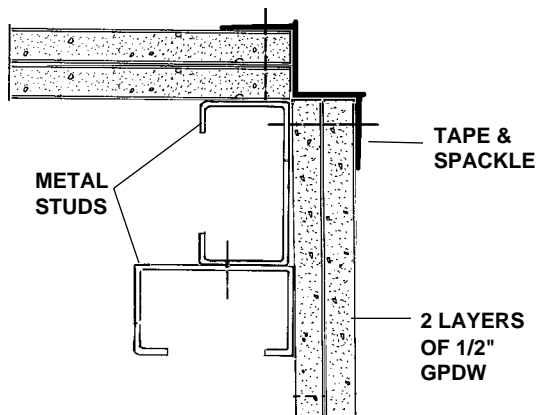

SCS-2X(100-100) & STUD WALLS
NO SCALE PLAN/SECTION

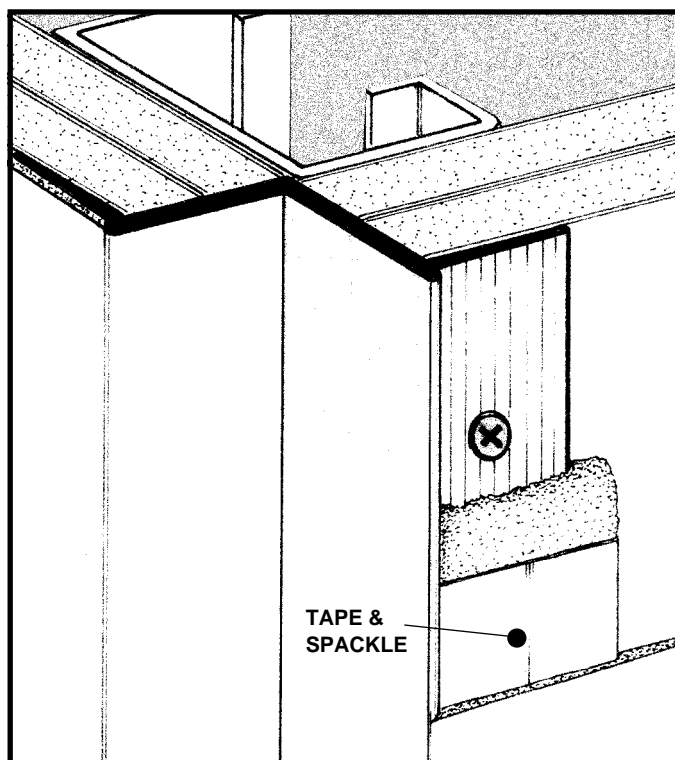

All details, methods and specifications are the exclusive property of Pitcon Softforms® LLC. Pitcon reserves the right to change any specifications or details without prior notification. All Softforms® profiles are available in standard 10' lengths ±1/8" (2.048 M). Other lengths are available as special order items. For custom shapes, sizes, or for special finishes, please contact the factory or your nearest Pitcon sales representative.

SCS-3X(050-050)

TRIPLE CORNER STEP 1/2" x 1/2"

SAMPLE SPECIFICATION

specify as: SOFTFORMS® Model # SCS-3X(050-050)

Pittcon SOFTFORMS® LLC

6409 Rhode Island Avenue Riverdale, MD 20737 (800) 637-7638 (301) 927-1000 Fax: (301) 699-8690	3330 W. Flower Street Phoenix, AZ 85017 (800) 637-7638 (602) 233-9100 Fax: (602) 233-9400
--	---

The extruded aluminum profile shall incorporate a continuous integral fin for surface contact to conventionally installed gypsum drywall. The fins shall be 7/8" wide and shall be tapered to the edge. The tapered fins shall be punched with holes staggered to accept standard screw fastening. A series of continuous grooves shall be extruded into the face of the fins to provide greater bonding surface. The extruded profiles shall be primed with corrosion-resistant primer compatible with materials normally in use in conjunction with commercial interiors, i.e.: joint compound, latex and enamel paints, and wall covering adhesives.

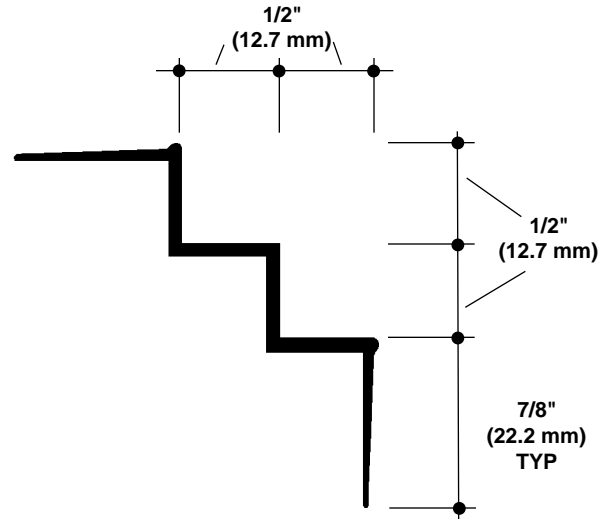

MATERIAL: Aluminum alloy.....6063 T5 or equal
Finish.....Factory primed

SCS-3X(050-050) TRIPLE CORNER STEP
NO SCALE FOR 1/2" GPDW

EXAMPLE DETAIL

For use with conventional metal stud construction and 5/8" GPDW.

The SCS-3X(050-050) permits a wide range of horizontal and vertical decorative treatments to walls, ceilings, soffits, column covers, etc. Screws through the grooved fins must always engage metal or wood substructure to ensure proper installation.

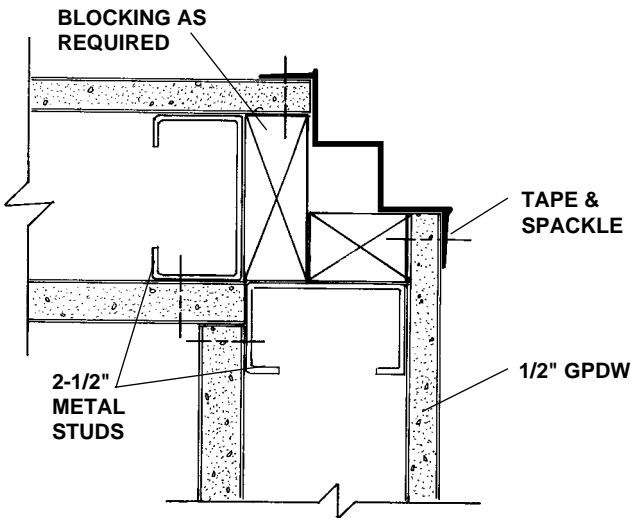

SCS-3X(050-050) 2-1/2" STUD WALL
NO SCALE PLAN/SECTION

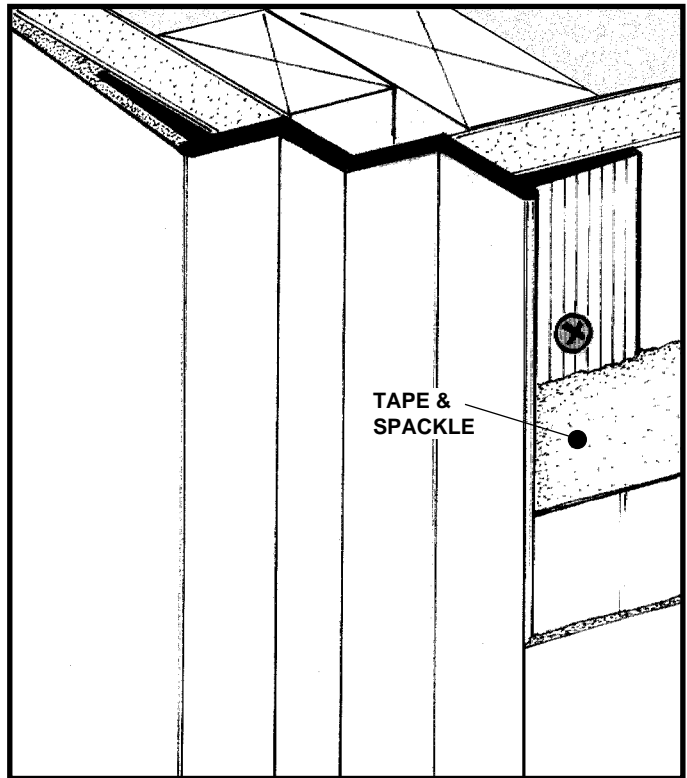

All details, methods and specifications are the exclusive property of Pittcon Softforms® LLC. Pittcon reserves the right to change any specifications or details without prior notification. All Softforms® profiles are available in standard 10' lengths ±1/8" (2.048 M). Other lengths are available as special order items. For custom shapes, sizes, or for special finishes, please contact the factory or your nearest Pittcon sales representative.

SCS-3X(063-063)

TRIPLE CORNER STEP 5/8" x 5/8"

SAMPLE SPECIFICATION

specify as: SOFTFORMS® Model # SCS-3X(063-063)

Pitcon SOFTFORMS® LLC

6409 Rhode Island Avenue
Riverdale, MD 20737
(800) 637-7638
(301) 927-1000
Fax: (301) 699-8690

3330 W. Flower Street
Phoenix, AZ 85017
(800) 637-7638
(602) 233-9100
Fax: (602) 233-9400

The extruded aluminum profile shall incorporate a continuous integral fin for surface contact to conventionally installed gypsum drywall. The fins shall be 7/8" wide and shall be tapered to the edge. The tapered fins shall be punched with holes staggered to accept standard screw fastening. A series of continuous grooves shall be extruded into the face of the fins to provide greater bonding surface. The extruded profiles shall be primed with corrosion-resistant primer compatible with materials normally in use in conjunction with commercial interiors, i.e.: joint compound, latex and enamel paints, and wall covering adhesives.

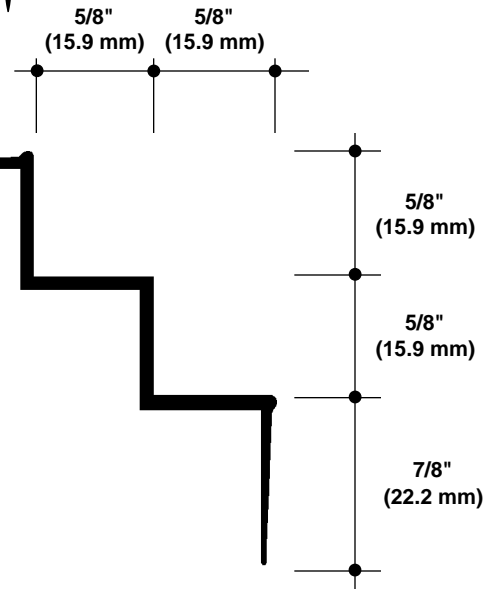

MATERIAL: Aluminum alloy.....6063 T5 or equal
Finish.....Factory primed

SCS-3X(063-063) TRIPLE CORNER STEP
NO SCALE FOR 5/8" GPDW

EXAMPLE DETAIL

For use with conventional metal stud construction and 5/8" GPDW.

The SCS-3X(063-063) permits a wide range of horizontal and vertical decorative treatments to walls, ceilings, soffits, column covers, etc. Screws through the grooved fins must always engage metal or wood substructure to ensure proper installation.

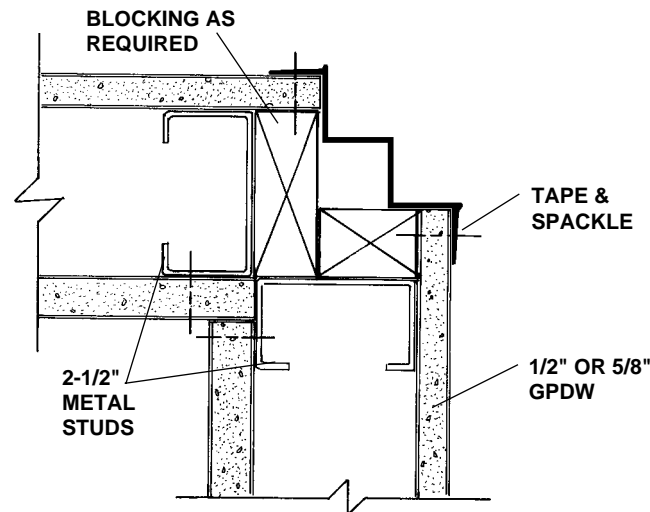

SCS-3X(063-063) 2-1/2" STUD WALL
NO SCALE PLAN/SECTION

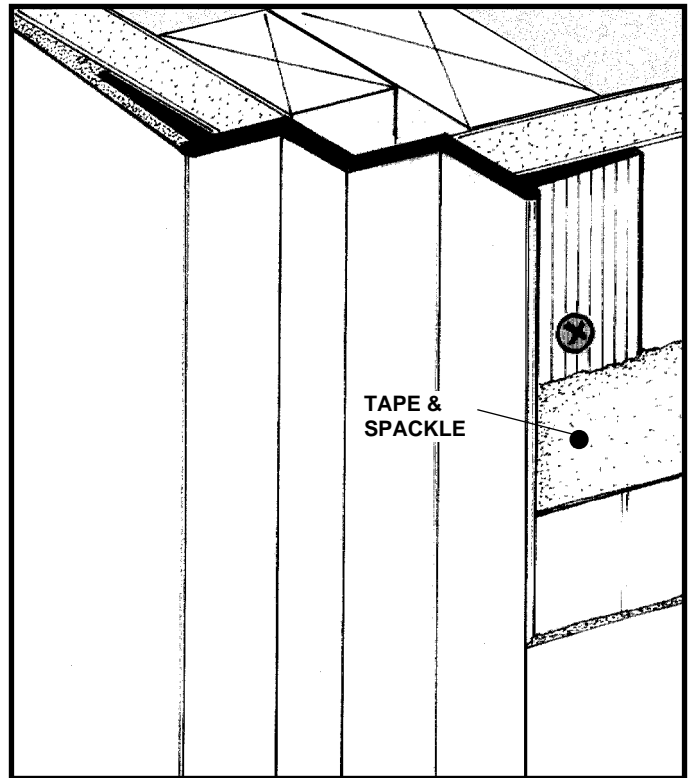

All details, methods and specifications are the exclusive property of Pitcon Softforms® LLC. Pitcon reserves the right to change any specifications or details without prior notification. All Softforms® profiles are available in standard 10' lengths ±1/8" (2.048 M). Other lengths are available as special order items. For custom shapes, sizes, or for special finishes, please contact the factory or your nearest Pitcon sales representative.

SCS-3X(100-100)

TRIPLE CORNER STEP 1" x 1"

SAMPLE SPECIFICATION

specify as: SOFTFORMS® Model # SCS-3X(100-100)

Pittcon SOFTFORMS® LLC

6409 Rhode Island Avenue	3330 W. Flower Street
Riverdale, MD 20737	Phoenix, AZ 85017
(800) 637-7638	(800) 637-7638
(301) 927-1000	(602) 233-9100
Fax: (301) 699-8690	Fax: (602) 233-9400

The extruded aluminum profile shall incorporate a continuous integral fin for surface contact to conventionally installed gypsum drywall. The fins shall be 7/8" wide and shall be tapered to the edge. The tapered fins shall be punched with holes staggered to accept standard screw fastening. A series of continuous grooves shall be extruded into the face of the fins to provide greater bonding surface. The extruded profiles shall be primed with corrosion-resistant primer compatible with materials normally in use in conjunction with commercial interiors, i.e.: joint compound, latex and enamel paints, and wall covering adhesives.

MATERIAL: Aluminum alloy.....6063 T5 or equal
Finish.....Factory primed

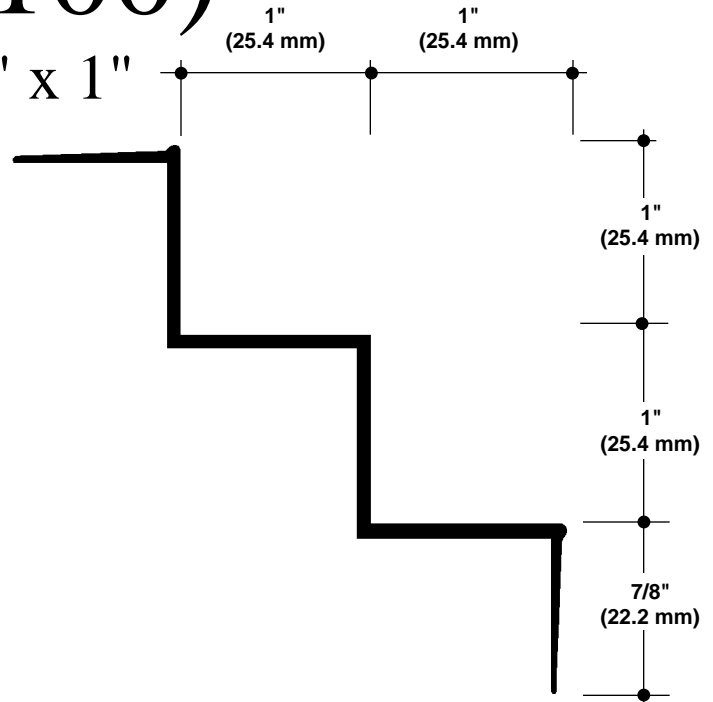

SCS-3X(100-100) TRIPLE CORNER STEP
NO SCALE SECTION

EXAMPLE DETAIL

For use with conventional metal stud construction and 1/2" or 5/8" GPDW.

The SCS-3X(100-100) permits a wide range of horizontal and vertical decorative treatments to walls, ceilings, soffits, column covers, etc. Screws through the grooved fins must always engage metal or wood substructure to ensure proper installation.

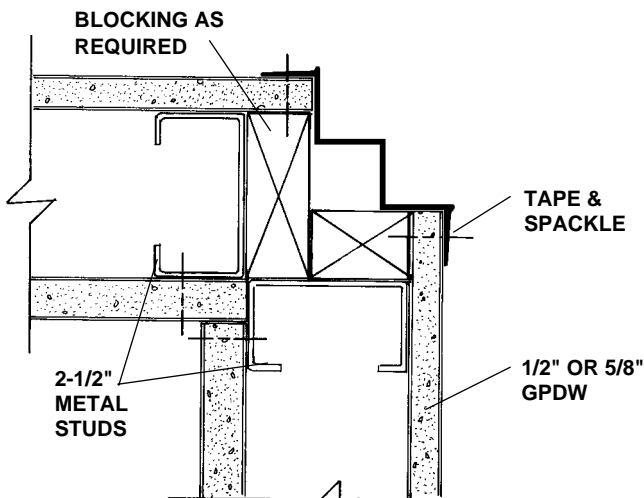

SCS-3X(100-100) 2 1/2" STUD WALL
NO SCALE PLAN/SECTION

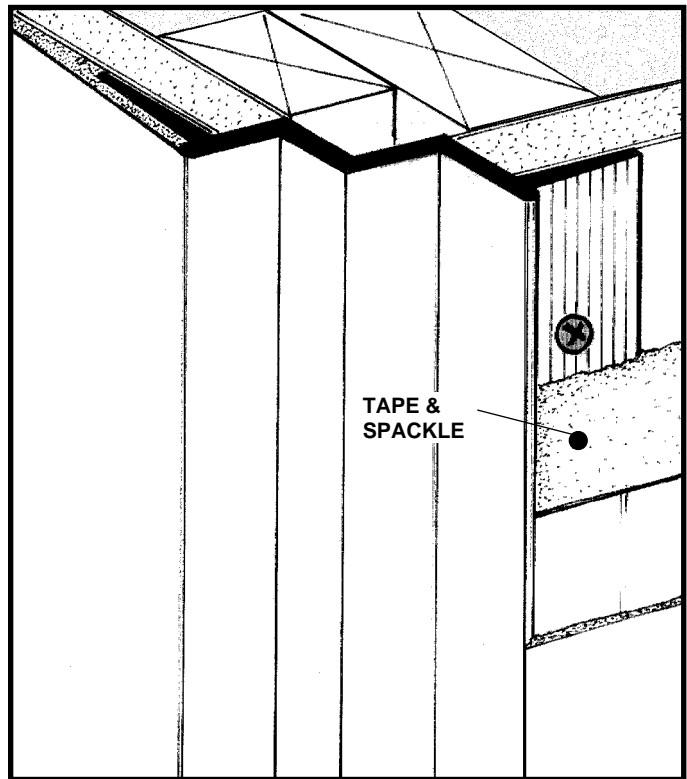

All details, methods and specifications are the exclusive property of Pittcon Softforms® LLC. Pittcon reserves the right to change any specifications or details without prior notification. All Softforms® profiles are available in standard 10' lengths ±1/8" (2.048 M). Other lengths are available as special order items. For custom shapes, sizes, or for special finishes, please contact the factory or your nearest Pittcon sales representative.

SCS-3X

CUSTOM CORNER STEP

SAMPLE SPECIFICATION

specify as: SOFTFORMS® Model # SCS-3X

Pitcon SOFTFORMS® LLC

6409 Rhode Island Avenue	3330 W. Flower Street
Riverdale, MD 20737	Phoenix, AZ 85017
(800) 637-7638	(800) 637-7638
(301) 927-1000	(602) 233-9100
Fax: (301) 699-8690	Fax: (602) 233-9400

The formed aluminum profile shall incorporate a continuous integral fin for surface contact to conventionally installed gypsum drywall. The formed profile shall be primed with corrosion-resistant primer compatible with materials normally in use in conjunction with commercial interiors, i.e.: joint compound, latex and enamel paints, and wall covering adhesives.

MATERIAL: Aluminum alloy.....3003 H-14 or equal
 Finish.....Factory primed
 Metal Thickness......090" typical

Note: Other thicknesses ranging from .062" to .125" are available upon request, with some restrictions applying. Check factory for your needs.

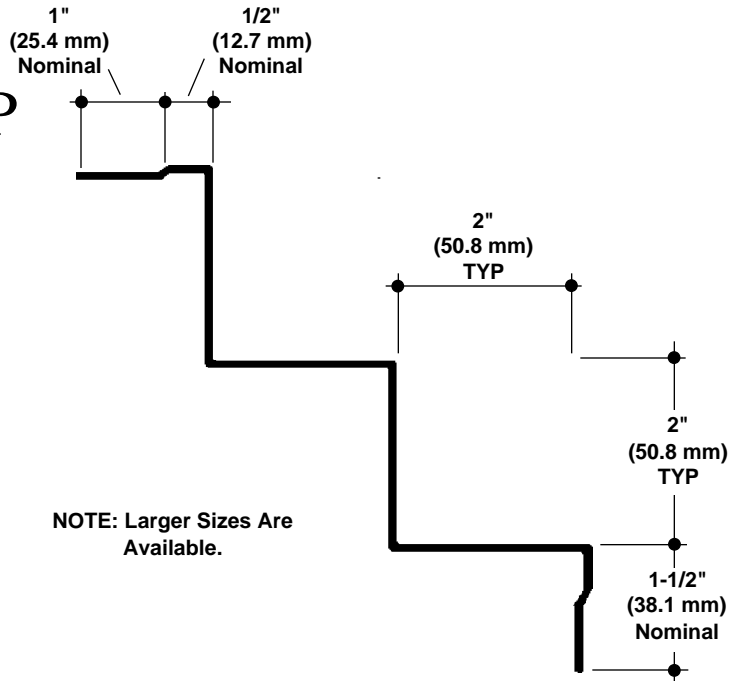

SCS-3X **TRIPLE CORNER STEP**
NO SCALE **SECTION**

EXAMPLE DETAIL

For use with 1/2" or 5/8" GPDW ceilings.

The SCS-3X may be used horizontally or vertically to create a multistep corner in widths specified. Screws through the tapered fins must always engage metal or wood substructure to ensure proper installation.

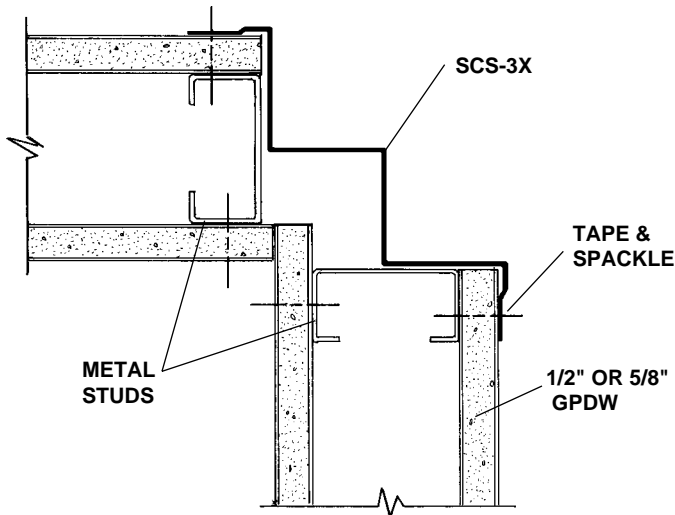

SCS-3X **STUD WALL**
NO SCALE **PLAN/SECTION**

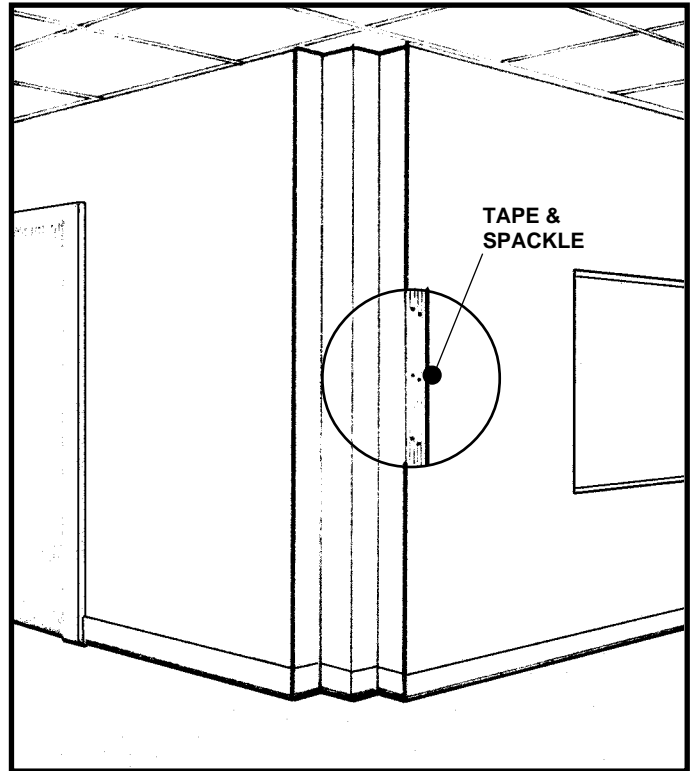

All details, methods and specifications are the exclusive property of Pitcon Softforms® LLC. Pitcon reserves the right to change any specifications or details without prior notification. All Softforms® profiles are available in standard 10' lengths ±1/8" (2.048 M). Other lengths are available as special order items. For custom shapes, sizes, or for special finishes, please contact the factory or your nearest Pitcon sales representative.

SCS-4X(033-050)

QUAD CORNER STEP 1/3" x 1/2"

SAMPLE SPECIFICATION

specify as: SOFTFORMS® Model # SCS-4X(033-050)

Pittcon SOFTFORMS® LLC

6409 Rhode Island Avenue Riverdale, MD 20737 (800) 637-7638 (301) 927-1000 Fax: (301) 699-8690	3330 W. Flower Street Phoenix, AZ 85017 (800) 637-7638 (602) 233-9100 Fax: (602) 233-9400
--	---

The extruded aluminum profile shall incorporate a continuous integral fin for surface contact to conventionally installed gypsum drywall. The fins shall be 7/8" wide and shall be tapered to the edge. The tapered fins shall be punched with holes staggered to accept standard screw fastening. A series of continuous grooves shall be extruded into the face of the fins to provide greater bonding surface. The extruded profiles shall be primed with corrosion-resistant primer compatible with materials normally in use in conjunction with commercial interiors, i.e.: joint compound, latex and enamel paints, and wall covering adhesives.

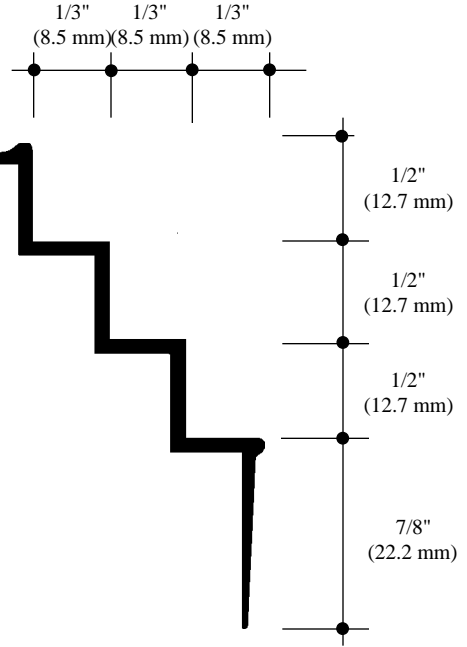

MATERIAL: Aluminum alloy.....6063 T5 or equal
Finish.....Factory primed

SCS-4X(033-050)

QUAD CORNER STEP

NO SCALE

FOR 1/2" OR 5/8" GPDW

EXAMPLE DETAIL

For use with conventional metal stud construction and 1/2" or 5/8" GPDW.

The SCS-4X(033-050) permits a wide range of horizontal and vertical decorative treatments to walls, ceilings, soffits, column covers, etc. Screws through the grooved fins must always engage metal or wood substructure to ensure proper installation.

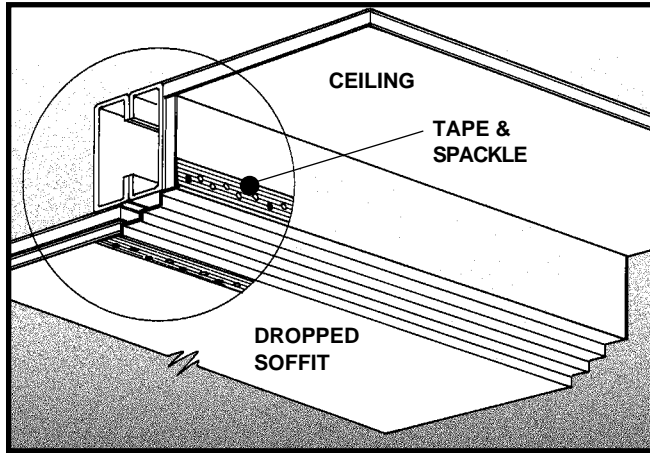

SCS-4X(033-050)

AT SOFFIT

NO SCALE

PERSPECTIVE

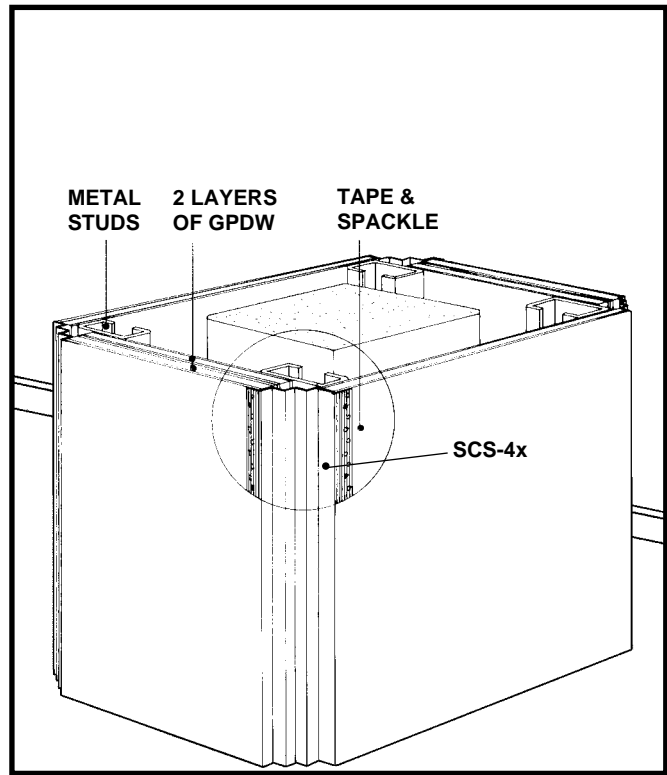

All details, methods and specifications are the exclusive property of Pittcon Softforms® LLC. Pittcon reserves the right to change any specifications or details without prior notification. All Softforms® profiles are available in standard 10' lengths ±1/8" (2.048 M). Other lengths are available as special order items. For custom shapes, sizes, or for special finishes, please contact the factory or your nearest Pittcon sales representative.

Softforms®

PREFORMED ARCHITECTURAL PROFILES
FOR DRYWALL CONSTRUCTION

SO 50

SO-LRP

CUSTOM OUTSIDE CORNER With Perpendicular Fins

SAMPLE SPECIFICATION

specify as: SOFTFORMS® Model # SO-LRP

Pitcon SOFTFORMS® LLC

6409 Rhode Island Avenue	3330 W. Flower Street
Riverdale, MD 20737	Phoenix, AZ 85017
(800) 637-7638	(800) 637-7638
(301) 927-1000	(602) 233-9100
Fax: (301) 699-8690	Fax: (602) 233-9400

The formed aluminum profile shall incorporate a continuous integral fin for surface contact to conventionally installed gypsum drywall. The formed profile shall be primed with corrosion-resistant primer compatible with materials normally in use in conjunction with commercial interiors, i.e.: joint compound, latex and enamel paints, and wall covering adhesives.

MATERIAL: Aluminum alloy.....3003 H-14 or equal
 Finish.....Factory primed
 Metal Thickness......090" typical

Note: Other thicknesses ranging from .062" to .125" are available upon request, with some restrictions applying. Check factory for your needs.

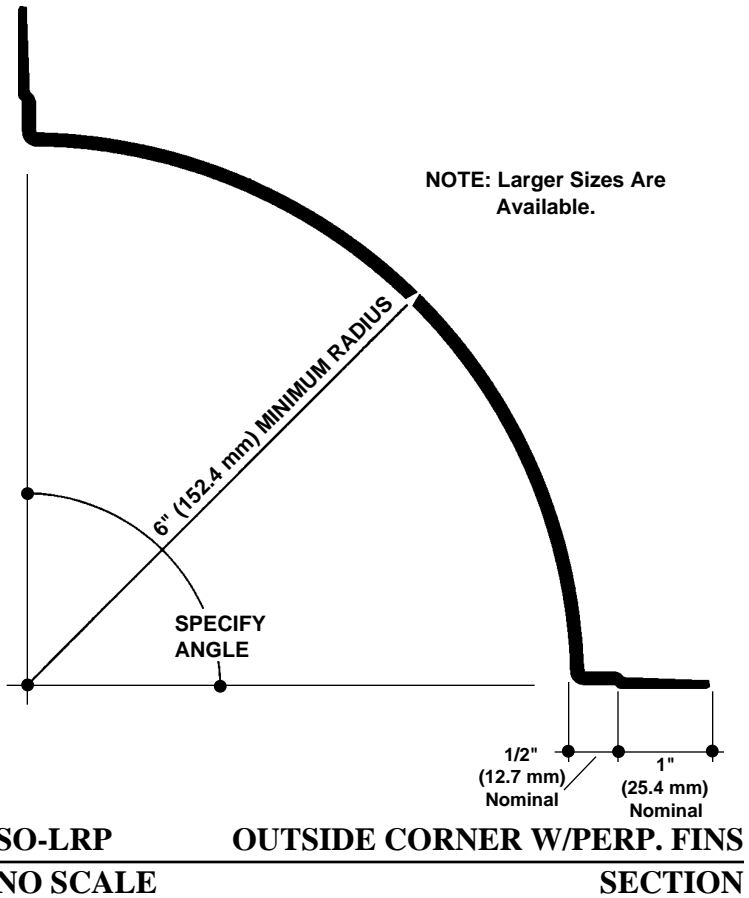

EXAMPLE DETAIL

For use with conventional metal stud construction and 1/2" or 5/8" GPDW.

The SO-LRP is a large radius outside corner or column cover with perpendicular fins for corner drywall constructions similar to that depicted here. Screws through the installation fins must always engage metal or wood substructure to ensure proper installation.

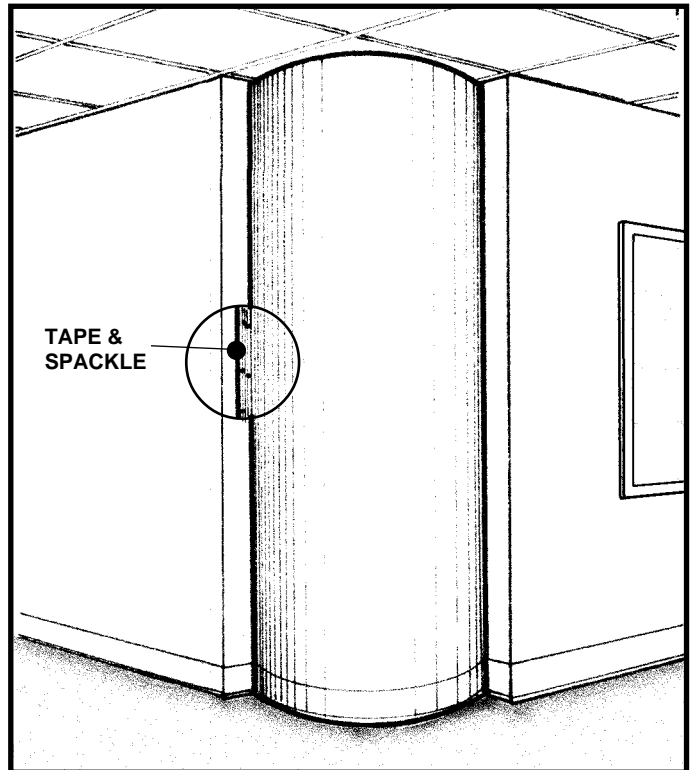
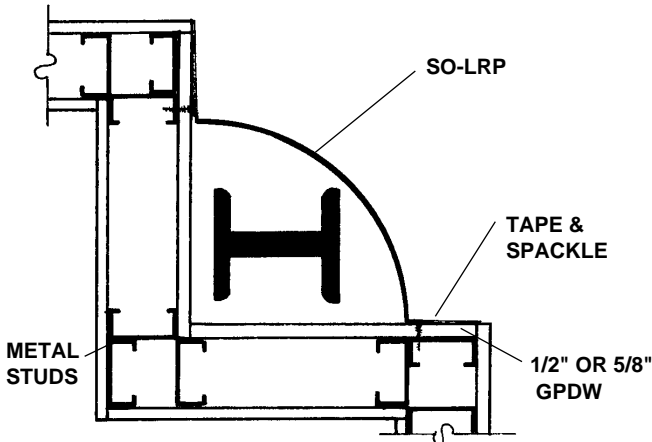

All details, methods and specifications are the exclusive property of Pitcon Softforms® LLC. Pitcon reserves the right to change any specifications or details without prior notification. All Softforms® profiles are available in standard 10' lengths ±1/8" (2.048 M). Other lengths are available as special order items. For custom shapes, sizes, or for special finishes, please contact the factory or your nearest Pitcon sales representative.

SO-LRT

CUSTOM OUTSIDE CORNER WITH TANGENTIAL FINS

SAMPLE SPECIFICATION

specify as: SOFTFORMS® Model # SO-LRT

Pittcon SOFTFORMS® LLC

6409 Rhode Island Avenue	3330 W. Flower Street
Riverdale, MD 20737	Phoenix, AZ 85017
(800) 637-7638	(800) 637-7638
(301) 927-1000	(602) 233-9100
Fax: (301) 699-8690	Fax: (602) 233-9400

The formed aluminum profile shall incorporate a continuous integral fin for surface contact to conventionally installed gypsum drywall. The formed profile shall be primed with corrosion-resistant primer compatible with materials normally in use in conjunction with commercial interiors, i.e.: joint compound, latex and enamel paints, and wall covering adhesives.

MATERIAL: Aluminum alloy.....3003 H-14 or equal
 Finish.....Factory primed
 Metal Thickness......090" typical

Note: Other thicknesses ranging from .062" to .125" are available upon request, with some restrictions applying. Check factory for your needs.

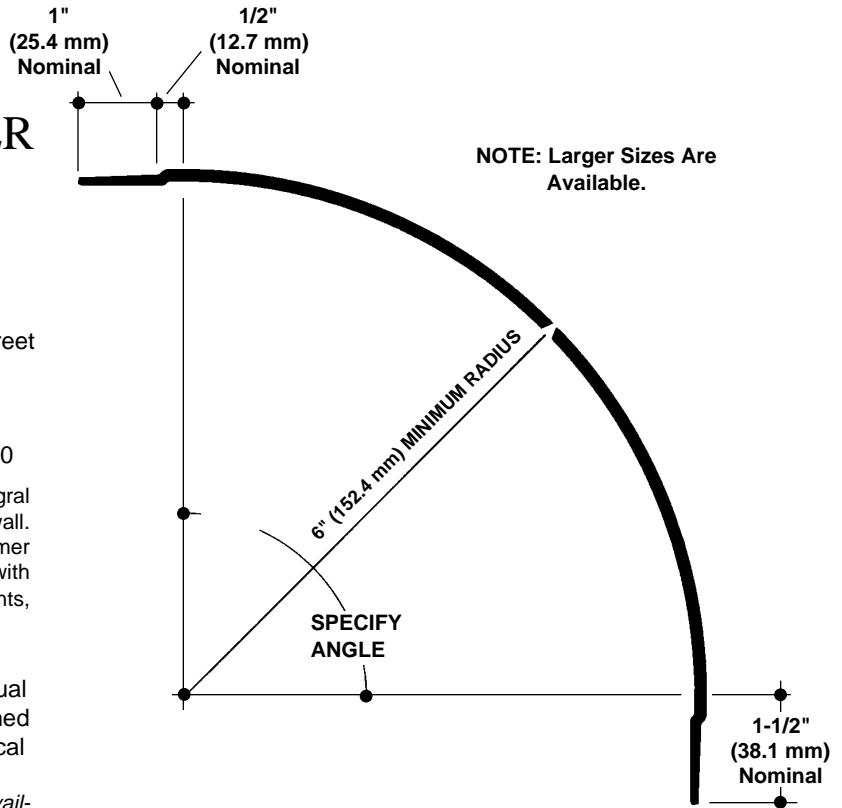

SO-LRT OUTSIDE CORNER W/TANGENT FINS
NO SCALE SECTION

EXAMPLE DETAIL

For use with conventional metal stud construction and 1/2" or 5/8" GPDW.

The SO-LRT is a large radius outside corner or column cover with perpendicular fins for corner drywall constructions similar to that depicted here. Screws through the installation fins must always engage metal or wood substructure to ensure proper installation.

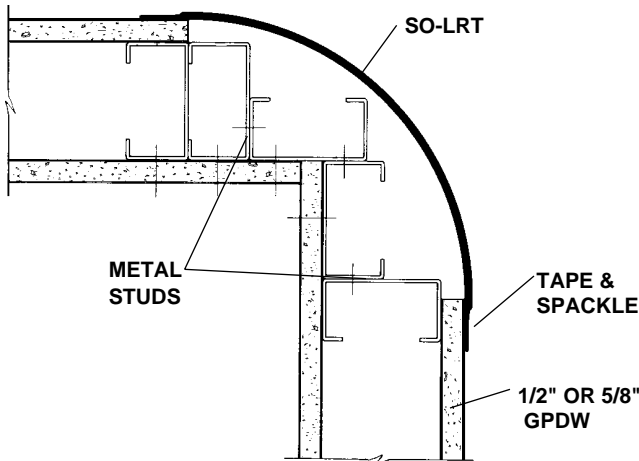

SO-LRT STUD WALL
NO SCALE PLAN/SECTION

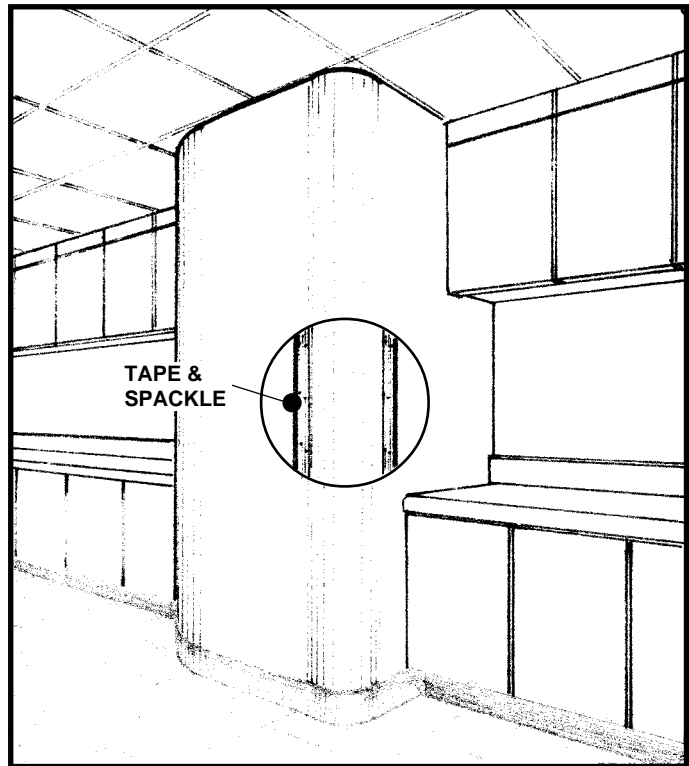

All details, methods and specifications are the exclusive property of Pittcon Softforms® LLC. Pittcon reserves the right to change any specifications or details without prior notification. All Softforms® profiles are available in standard 10' lengths ±1/8" (2.048 M). Other lengths are available as special order items. For custom shapes, sizes, or for special finishes, please contact the factory or your nearest Pittcon sales representative.

SO-LRPT

CUSTOM OUTSIDE CORNER With One Perpendicular Fin

SAMPLE SPECIFICATION

specify as: SOFTFORMS® Model # SO-LRPT

Pittcon SOFTFORMS® LLC

6409 Rhode Island Avenue Riverdale, MD 20737 (800) 637-7638 (301) 927-1000 Fax: (301) 699-8690	3330 W. Flower Street Phoenix, AZ 85017 (800) 637-7638 (602) 233-9100 Fax: (602) 233-9400
--	---

The formed aluminum profile shall incorporate a continuous integral fin for surface contact to conventionally installed gypsum drywall. The formed profile shall be primed with corrosion-resistant primer compatible with materials normally in use in conjunction with commercial interiors, i.e.: joint compound, latex and enamel paints, and wall covering adhesives.

MATERIAL: Aluminum alloy.....3003 H-14 or equal
Finish.....Factory primed
Metal Thickness......090" typical

Note: Other thicknesses ranging from .062" to .125" are available upon request, with some restrictions applying. Check factory for your needs.

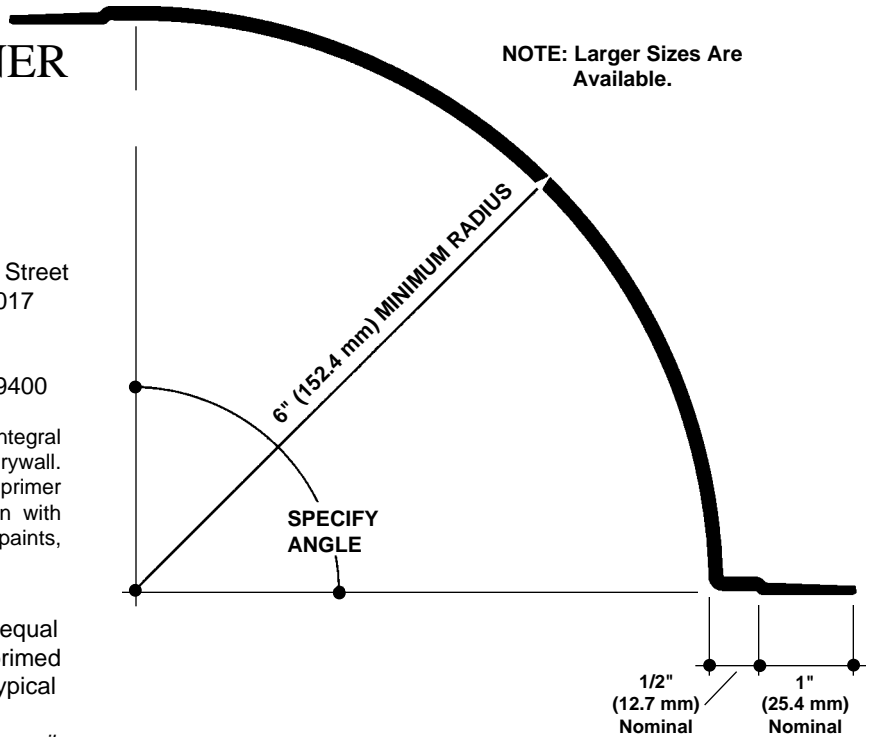

SO-LRPT

OUTSIDE CORNER

NO SCALE

W/ONE PERPENDICULAR FIN

EXAMPLE DETAIL

For use with conventional metal stud construction and 1/2" or 5/8" GPDW.

The SO-LRPT is a large radius outside corner or column with perpendicular fins for corner drywall constructions similar to that depicted here. Screws through the grooved fins must always engage metal or wood substructure to ensure proper installation.

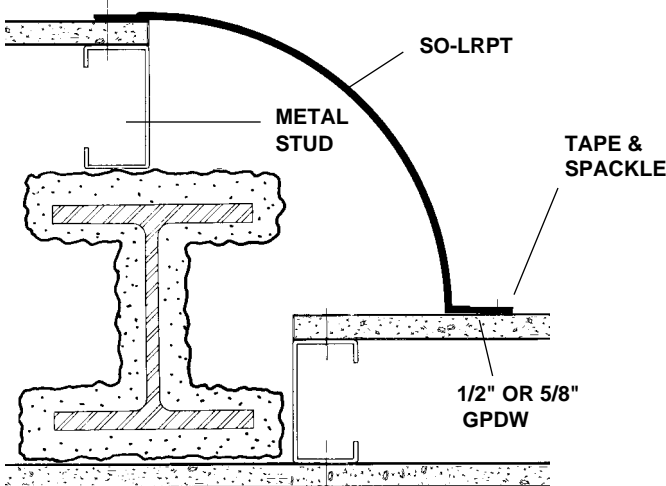

SO-LRPT CUSTOM CORNER

NO SCALE

PLAN/SECTION

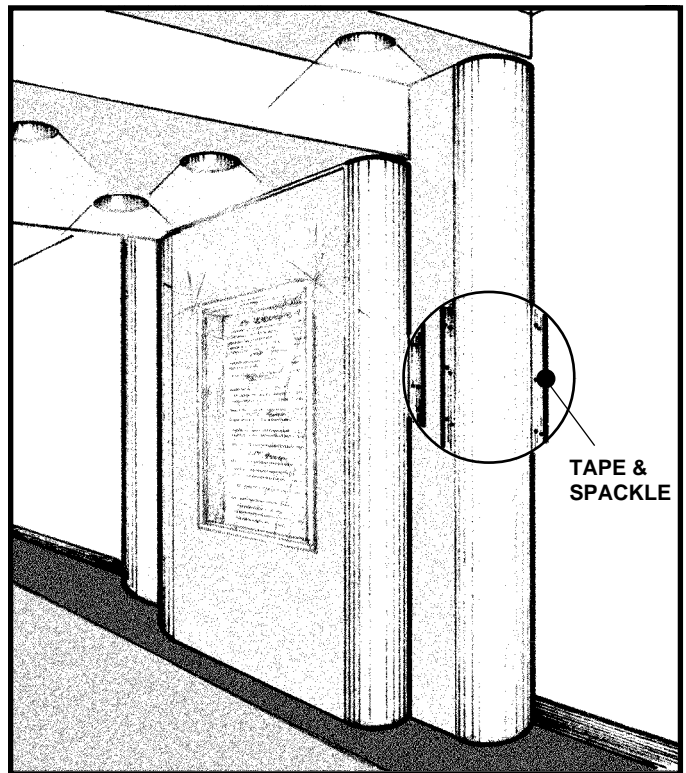

All details, methods and specifications are the exclusive property of Pittcon Softforms® LLC. Pittcon reserves the right to change any specifications or details without prior notification. All Softforms® profiles are available in standard 10' lengths ±1/8" (2.048 M). Other lengths are available as special order items. For custom shapes, sizes, or for special finishes, please contact the factory or your nearest Pittcon sales representative.

Softforms®

PREFORMED ARCHITECTURAL PROFILES
FOR DRYWALL CONSTRUCTION

SO 53

SO/SI-LRT

CUSTOM INSIDE/OUTSIDE CORNER SET

SAMPLE SPECIFICATION

specify as: SOFTFORMS® Model # SO/SI-LRT

Pittcon SOFTFORMS® LLC

6409 Rhode Island Avenue	3330 W. Flower Street
Riverdale, MD 20737	Phoenix, AZ 85017
(800) 637-7638	(800) 637-7638
(301) 927-1000	(602) 233-9100
Fax: (301) 699-8690	Fax: (602) 233-9400

The formed aluminum profile shall incorporate a continuous integral fin for surface contact to conventionally installed gypsum drywall. The formed profile shall be primed with corrosion-resistant primer compatible with materials normally in use in conjunction with commercial interiors, i.e.: joint compound, latex and enamel paints, and wall covering adhesives.

MATERIAL: Aluminum alloy.....3003 H-14 or equal
 Finish.....Factory primed
 Metal Thickness......090" typical

Note: Other thicknesses ranging from .062" to .125" are available upon request, with some restrictions applying. Check factory for your needs.

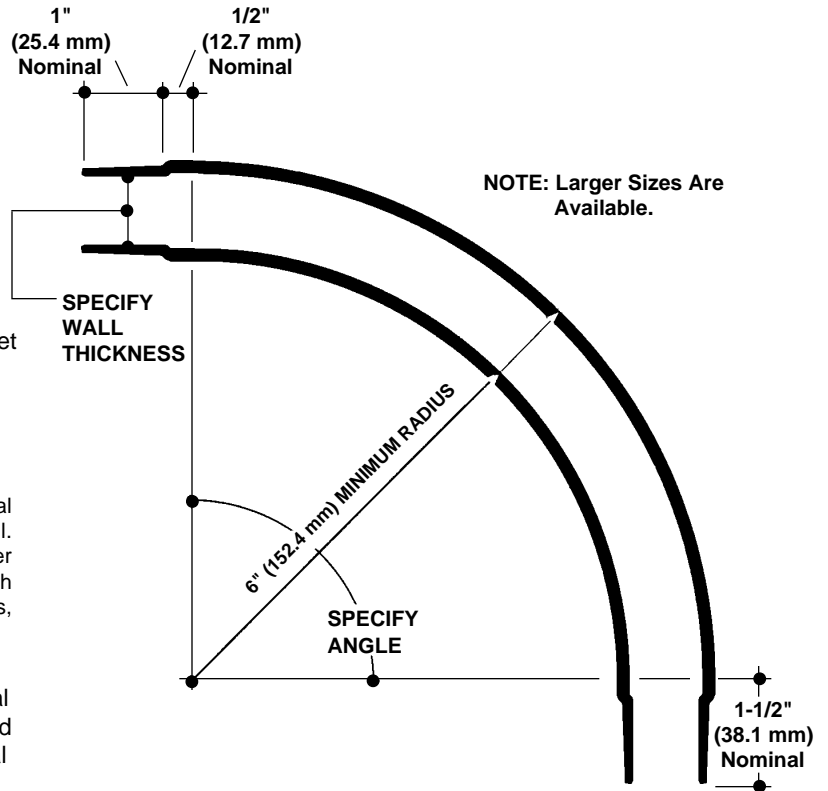

SO/SI-LRT
NO SCALE

INSIDE/OUTSIDE CORNER SET
SECTION

EXAMPLE DETAIL

For use with conventional metal stud construction and 1/2" or 5/8" GPDW.

The SO/SI-LRT set is a constant thickness inside/outside corner for drywall constructions similar to that depicted here. Screws through the installation fins must always engage metal or wood substructure to ensure proper installation.

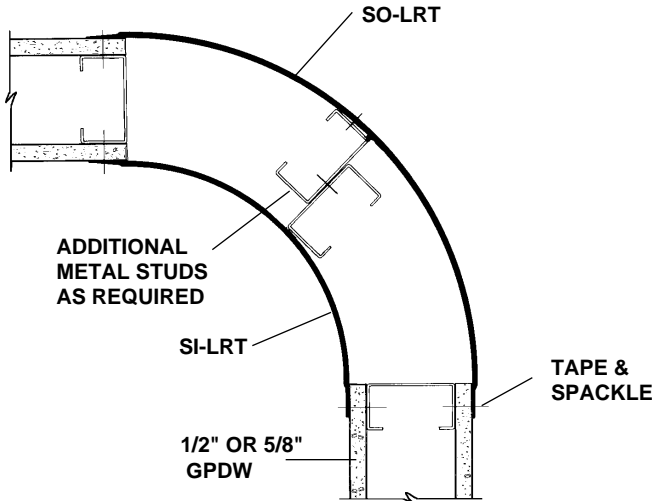

SO/SI-LRT
NO SCALE

STUD WALL
PLAN/SECTION

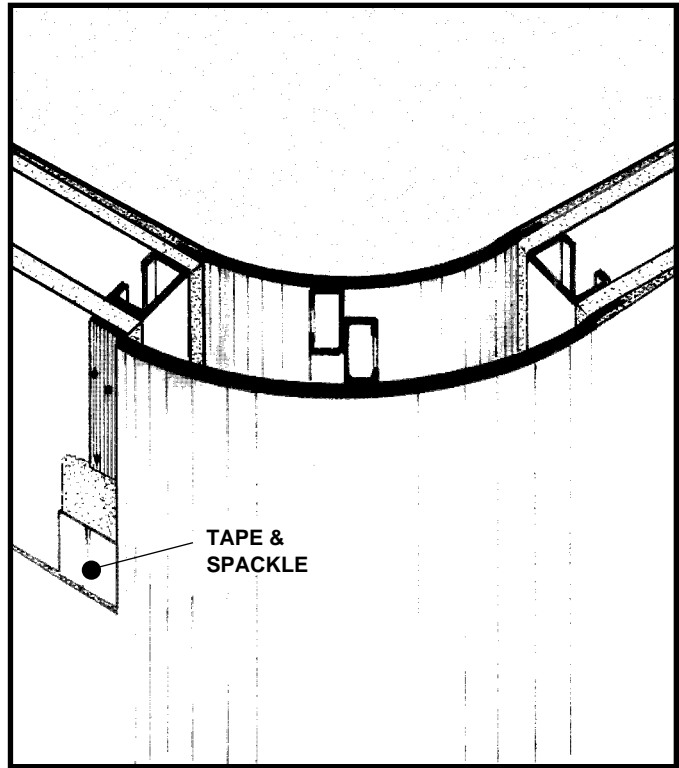

All details, methods and specifications are the exclusive property of Pittcon Softforms® LLC. Pittcon reserves the right to change any specifications or details without prior notification. All Softforms® profiles are available in standard 10' lengths ±1/8" (2.048 M). Other lengths are available as special order items. For custom shapes, sizes, or for special finishes, please contact the factory or your nearest Pittcon sales representative.



www.dcs-sales.com

8805 Tamiami Trail North, Suite 107
Naples, FL 34108

Florida
Thomas Schreiber
Sales Representative

tom@dcs-sales.com

(407) 648-5348 Phone

(407) 505-4336 Fax

Puerto Rico, US Virgin Islands - Caribbean
Island groups-Lucayan Archipelago
Greater Antilles, Lesser Antilles, Bahamas